



# GS-8000 SERIES

Heavy Duty Supersize CNC Turning Centers

## HEAVY DUTY SUPERSIZE CNC TURNING CENTERS

With leading technologies and high quality components, the GS-8000 series heavy duty CNC turning center combines a high rigidity box way bed with extra large diameter servo indexing turret and powerful gear spindle structure to provide you with efficient machining performance for large diameter and extra long work pieces. Meanwhile, with the optional live tooling turret and Y-axis, the GS-8000 series can easily accomplish multi-tasking operations for large and complex work pieces to fulfill various machining needs for today and tomorrow.

- ▶ 3-step gear box is driven by FANUC spindle motor with 45 kW maximum torque to provide excellent heavy duty cutting capability.
- ▶ The low center of gravity slant bed and wedge saddle design provide a super rigid structure.
- ▶ The optional Y-axis travel is of 320 mm which provides high precision and high efficiency machining performance.
- ▶ Fully enclosed splashguards keep chips and coolant contained for a safe clean working environment.



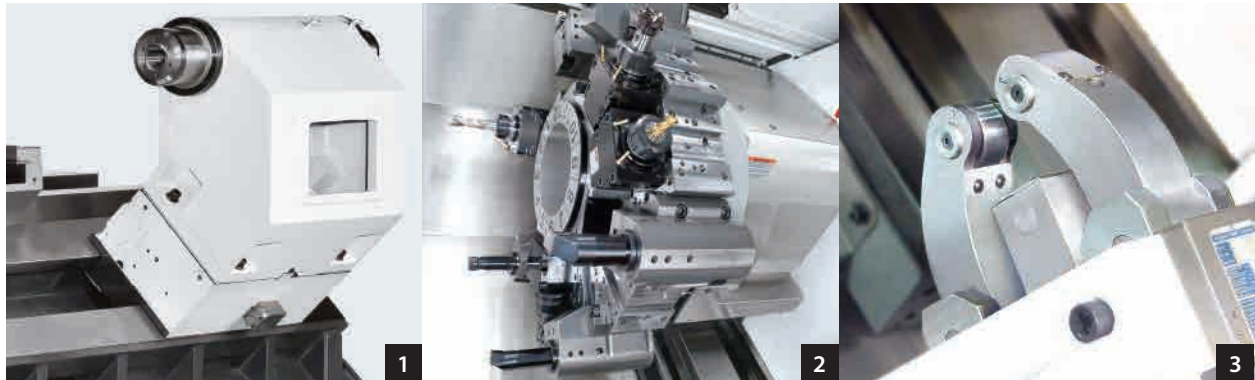

- 1** The MT#6 built-in bearing quill provides greater rigidity for heavy loads. The extension and retraction of the quill is programmable and pressure is adjustable. The software simplifies the positioning procedure of the programmable tailstock.
- 2** Working with the live tooling turret and C-axis control enables the machine to perform multiple tasks such as turning, milling, drilling, and tapping. It can prevent machining error causing by moving the work piece from one machine to another thus saving cycle time and manpower.
- 3** The optional hydraulic steady rest can support work pieces up to  $\varnothing$  460 mm diameter, which provides the best support for large work piece.



(GS-8000L<sup>2</sup> series model shown with optional accessories.)

## HIGH RIGIDITY CONSTRUCTION

- ▶ The low center of gravity heavy duty slant bed design provide a super rigid foundation for the headstock, turret, and tailstock.
- ▶ By using Finite Element Methods ( FEM ), optimal reinforce ribbings are directly cast into the one-piece bed structure. Mechanical rigidity has been increased by more than 30 % when compared to conventional designs. The GS-8000 series can provide both heavy cutting and high precision capabilities. More rigidity also means extended tool life.
- ▶ Built to endure years and years of rigorous high production turning, the heavily ribbed, one-piece thermally balanced bed and casting components are of MEEHANITE casting.
- ▶ MEEHANITE grade cast iron is capable of withstanding much greater stress without deforming and provides maximum vibration damping, which result in a machine that will outlast and outperform the competition.
- ▶ All spindle and servo motors, including drives, are FANUC alpha *i* series components to ensure peak machining performance and accuracy.

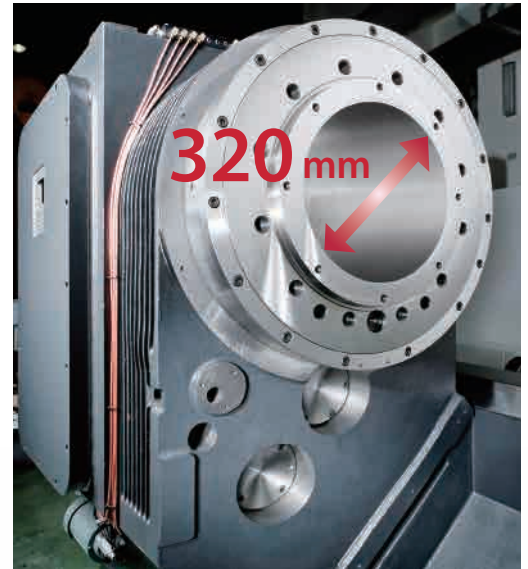

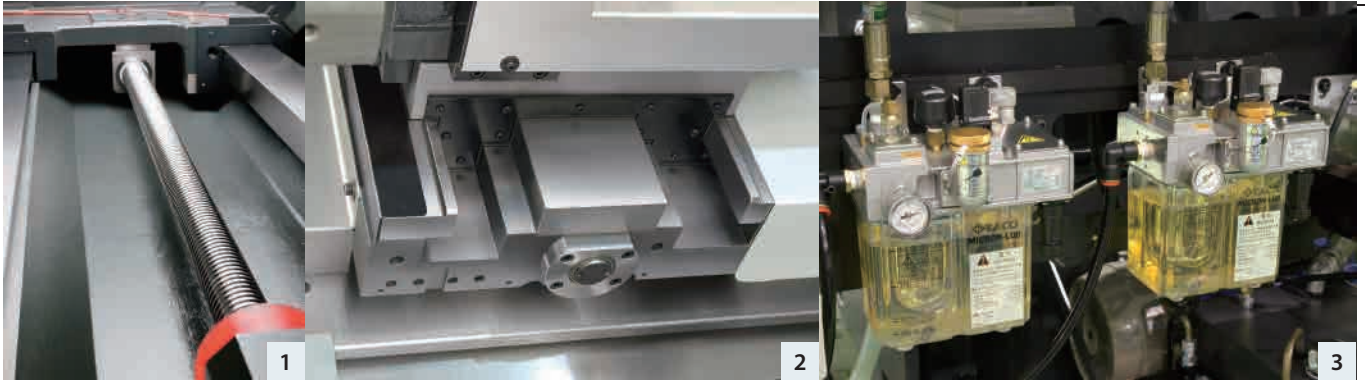

- 1** C3 class hardened and precision ground ball screws ensure the highest accuracy and durability possible. Plus, pretension on all axes minimizes thermal distortion.
- 2** Extra wide hardened and ground box ways are directly formed into the machine bed and saddle during the casting process. They are precision machined and widely spaced for maximum strength. The box way design also provides the rigidity needed for heavy duty and interrupted turning applications.
- 3** The oil mist system can evenly and efficiently lubricate the spindle bearings to prevent thermal expansion while ensuring machining accuracy.

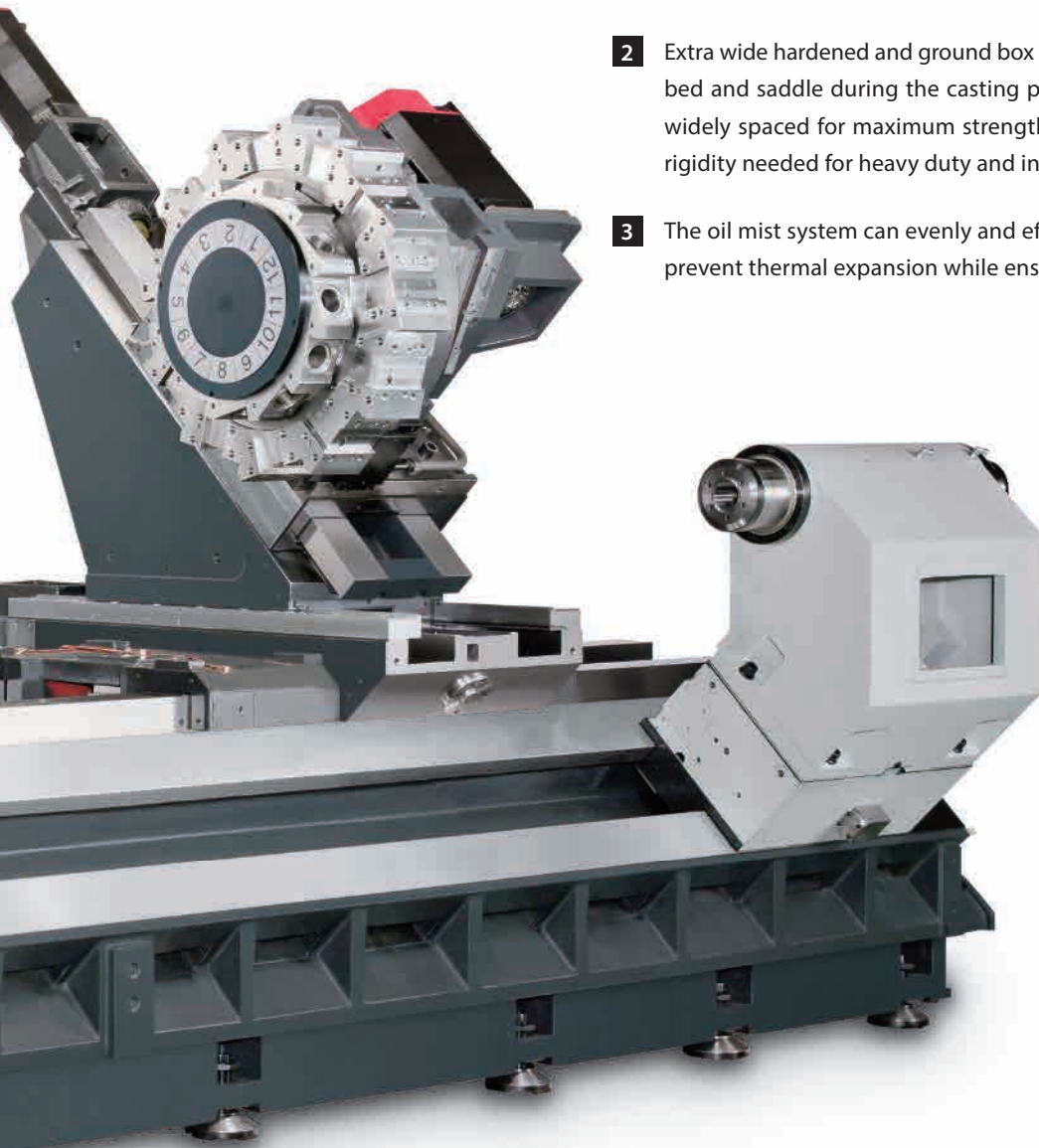

( Casting structure of GS-8000L<sup>2</sup>Y model shown. )

## ULTIMATE TURNING POWER

- ▶ High precision bearings are directly assembled for maximum level of support and precision. Bearing configuration is designed for heavy-duty cutting with ultra-smooth performance and long term durability with a higher level of accuracy.
- ▶ With over 7,330 N-m of torque available on the low speed of the 3-speed gear box, turning tough material with big diameter is now a simple task.
- ▶ Standard spindle orientation feature allows the spindle to stop at desired programmed position. Useful in broaching and manual part loading applications where a fixed spindle position is required.

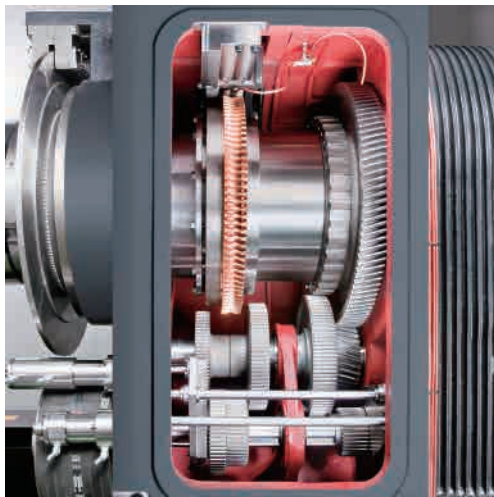

### Sample Work Pieces

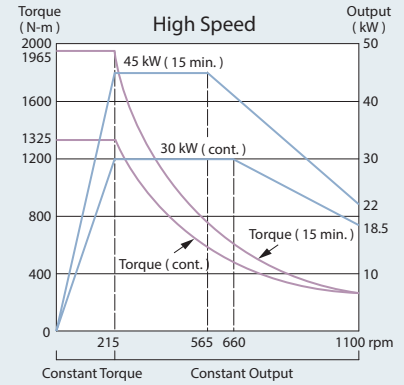
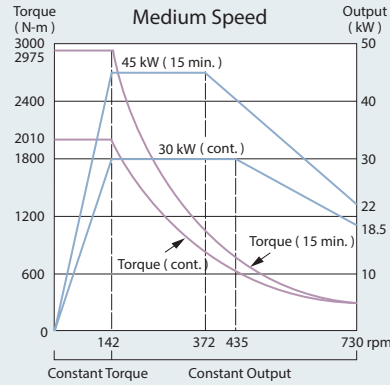
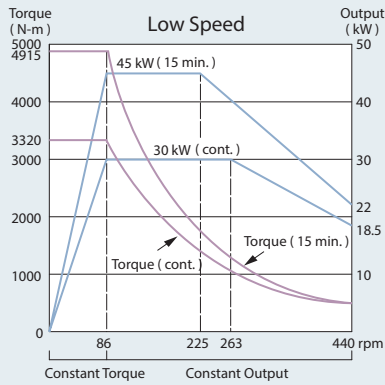
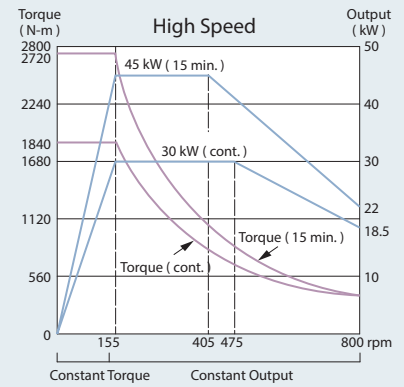
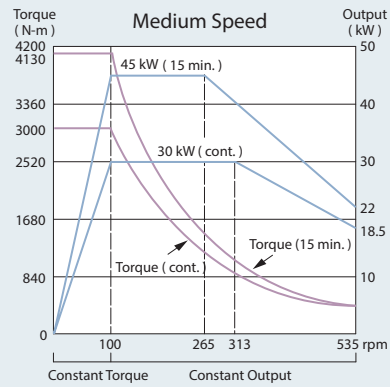
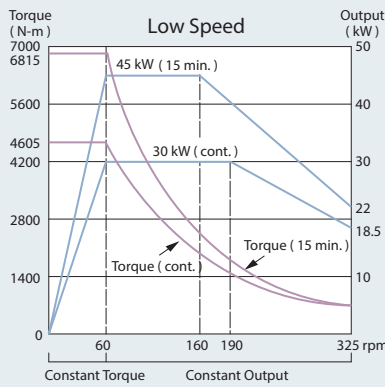
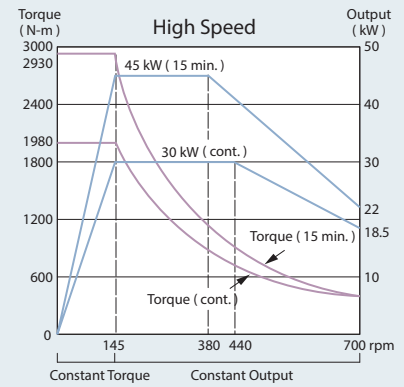
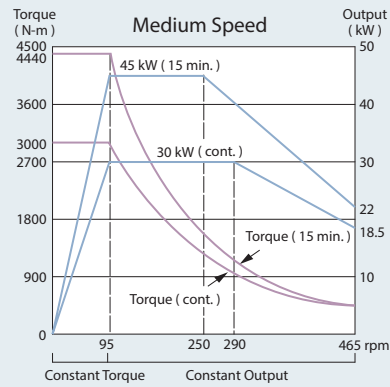
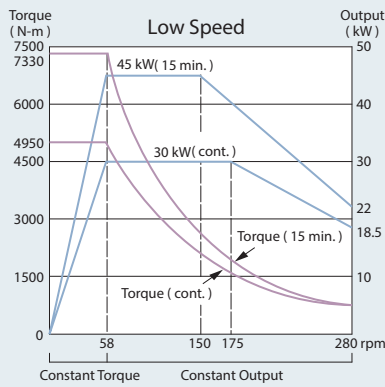

## Spindle Output

Hole through spindle  $\varnothing$  205 mmHole through spindle  $\varnothing$  260 mmHole through spindle  $\varnothing$  320 mm

## Front + Rear Chuck

- By installing air or manual chucks on both the front and rear of the spindle, it becomes possible to machine the ends of long work pieces. This configuration is especially useful in threading pipes.

Rear chuck

Work piece

Front chuck

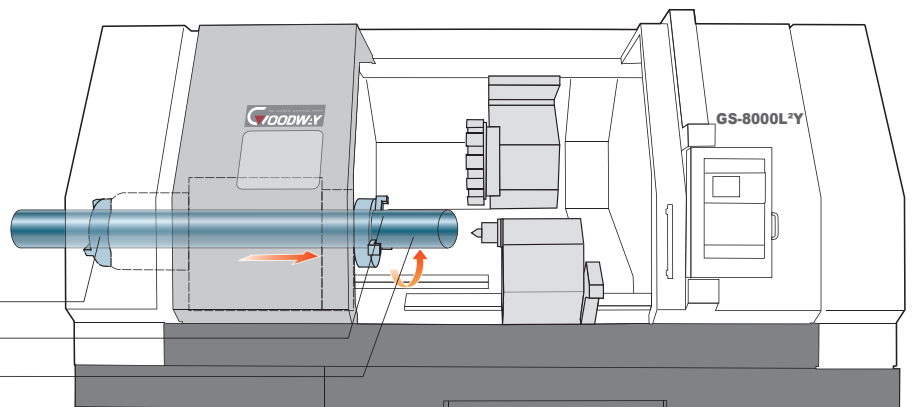

## ADVANCED TURRET TECHNOLOGY

- ▶ The curvature of the CURVIC teeth provides a very unique self-centering feature and wider uniform tooth contact throughout all the teeth. The CURVIC teeth are hardened to HRC 58, which ensures the coupling retains its high accuracy characteristics over long periods of use.
- ▶ Ø 450 mm diameter super high precision CURVIC couplings with 12,000 Kg of clamping force ensures abundant turret rigidity for all cutting conditions.
- ▶ The 12-station heavy-duty servo indexing turret achieves 0.5 second indexing times for adjacent stations and 1.5 second times for stations at the opposite end of the disk turret.
- ▶ The standard 12-station turret is capable of turning Ø 380 mm diameter work pieces without causing interference even when using boring tools.

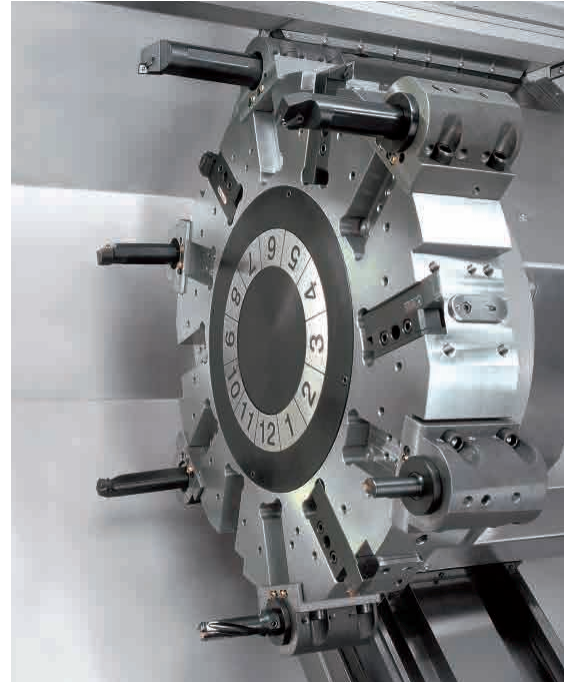
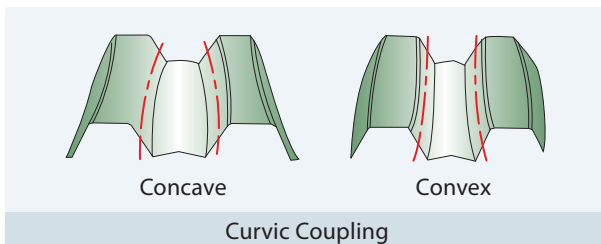

## LIVE TOOLING TURRETS

- ▶ Working with the live tooling turret and C-axis control enables the machine to perform multiple tasks such as turning, milling, drilling, and tapping. It can prevent machining error causing by moving the work piece from one machine to another thus saving cycle time and manpower.
- ▶ More powerful than a standard 40-taper machining center, the live tooling turret is driven by a 9 kW ( 30 min. ) AC double wound high torque spindle motor to provide ample power, now, even the toughest of jobs may be tackled without a sweat.
- ▶ The 12-station live tooling turret offers 12 stations available for live tooling, live tools rotate in working position only to reduce power loss and heat.
- ▶ GOODWAY live tooling turret utilizes advance servo indexing technology to achieve 0.5 second indexing times for adjacent stations and 1.5 second for stations at the opposite end of the disk.

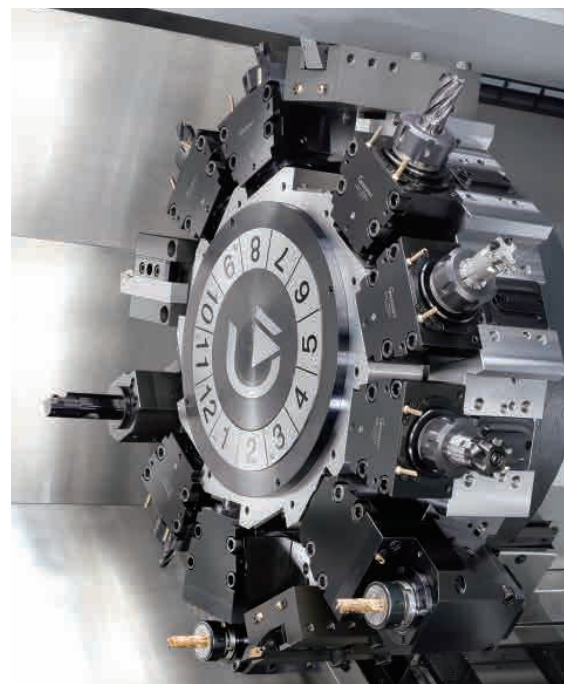



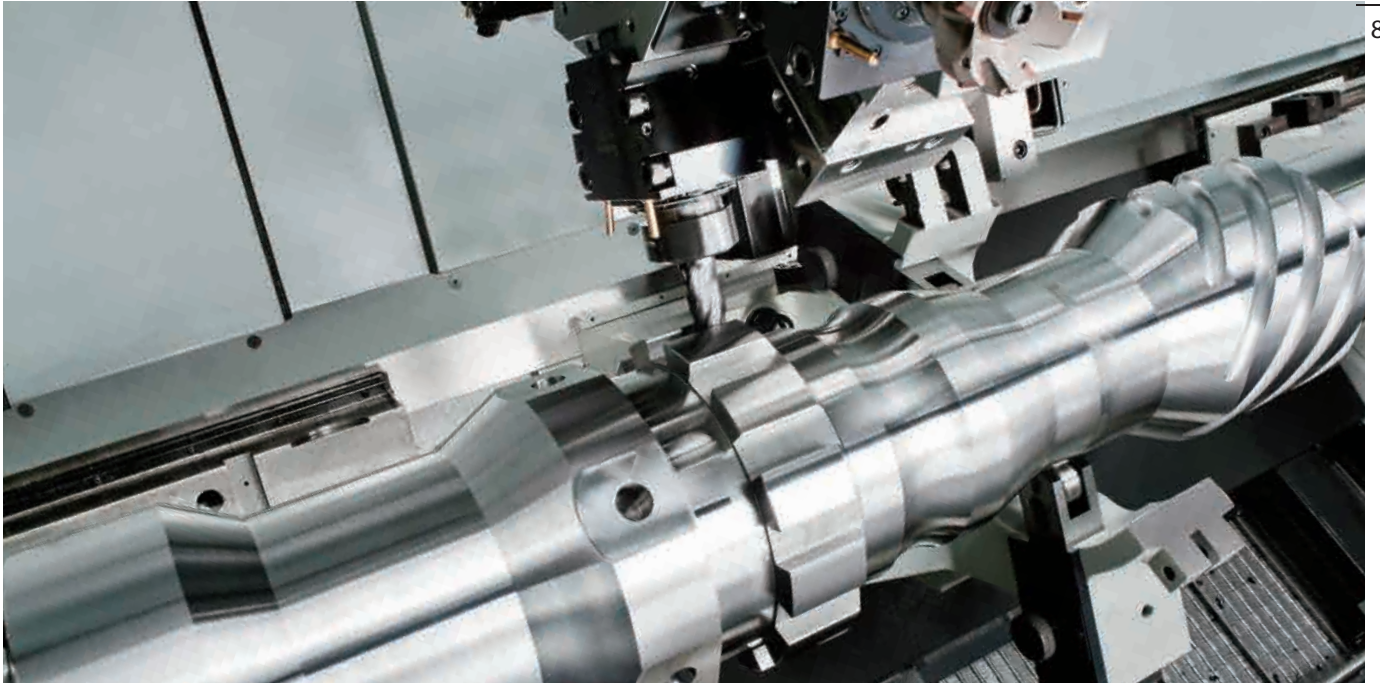

## ULTIMATE C-AXIS SPINDLE

- ▶ The Cf-axis and disk brake system provide the most rigid and powerful type of C-axis control on the market today.
- ▶ Working with the live tooling turret, the Cf-axis and disk brake system enables the machine to perform multiple tasks, such as drilling, tapping, and milling operations, including cylindrical and polar coordinate interpolations, resembling a 4th-axis rotary table on a machining center.
- ▶ With the FANUC servo motor generating an ultra high resolution of 1,000,000 pulses per spindle rotation and high torque, machined surface finishes are much superior than Cs-axis ( driven by spindle motor ) equipped machines. Plus, dynamic accuracy is within  $\pm 0.02^\circ$  even under heavy cutting loads.

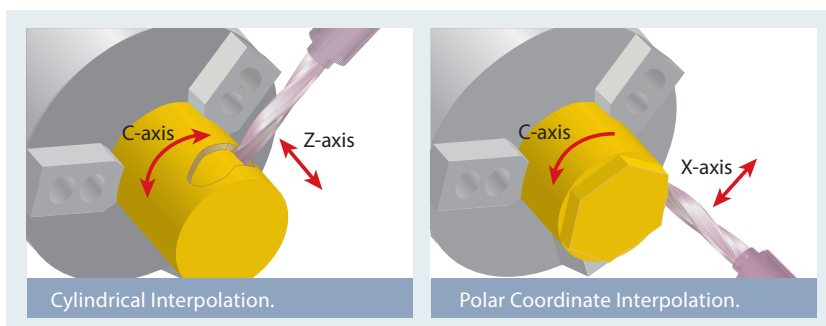

### Cf-axis Output

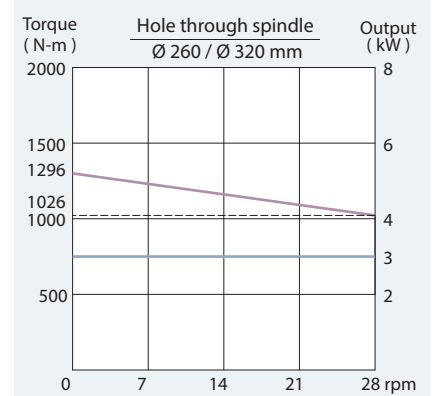
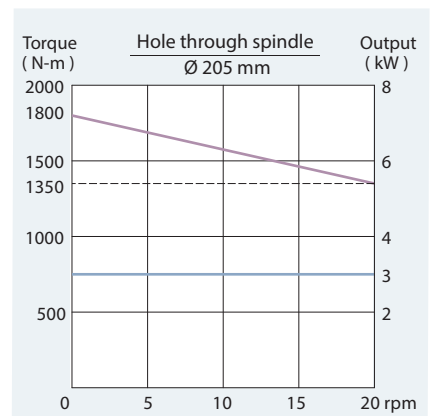

## Y-AXIS MACHINING CAPABILITY

Super large Y-axis travel is of 320 mm, which can easily fulfill machining conditions for large size work pieces in aerospace, shipbuilding and energy industries.

Super large Y-axis travel

**320 mm = ± 160 mm**

- ▶ Y-axis control further enhances multi-tasking live tooling capabilities and improves various machining precision. High precision grooving and X-axis off-center drilling are enabled.
- ▶ The low center of gravity box way is designed with a wide span structure to increase overall rigidity.
- ▶ The 45° angle of X and Y axes allows the center of gravity of the turret to remain in the saddle guide way to ensure machining accuracy and decrease distortion.

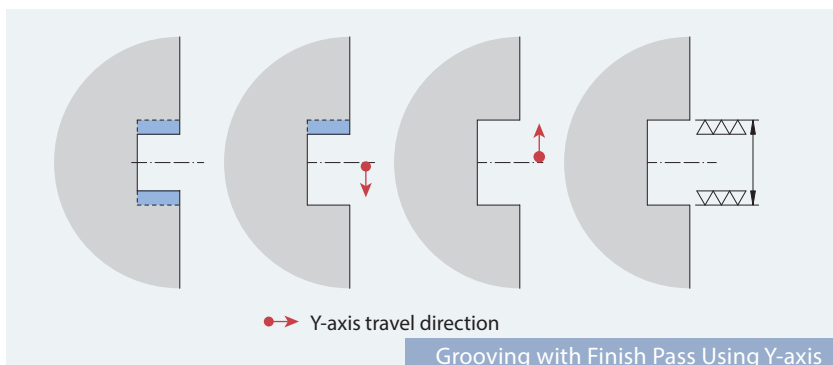
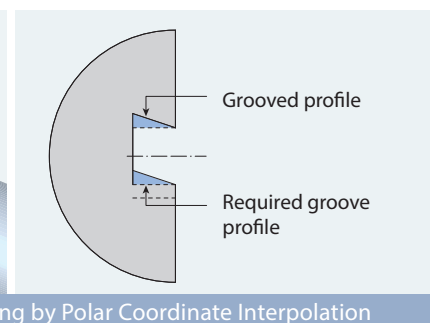
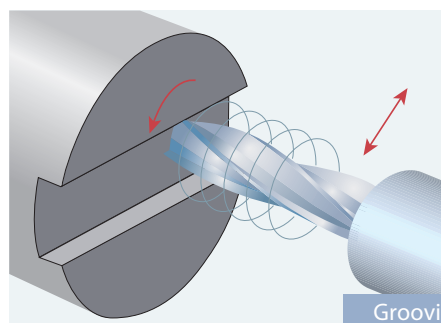
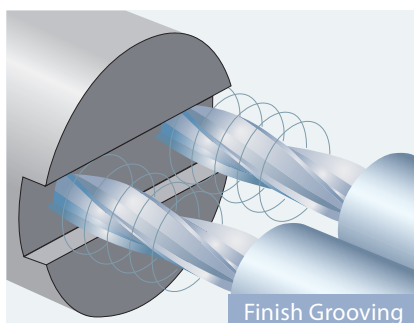
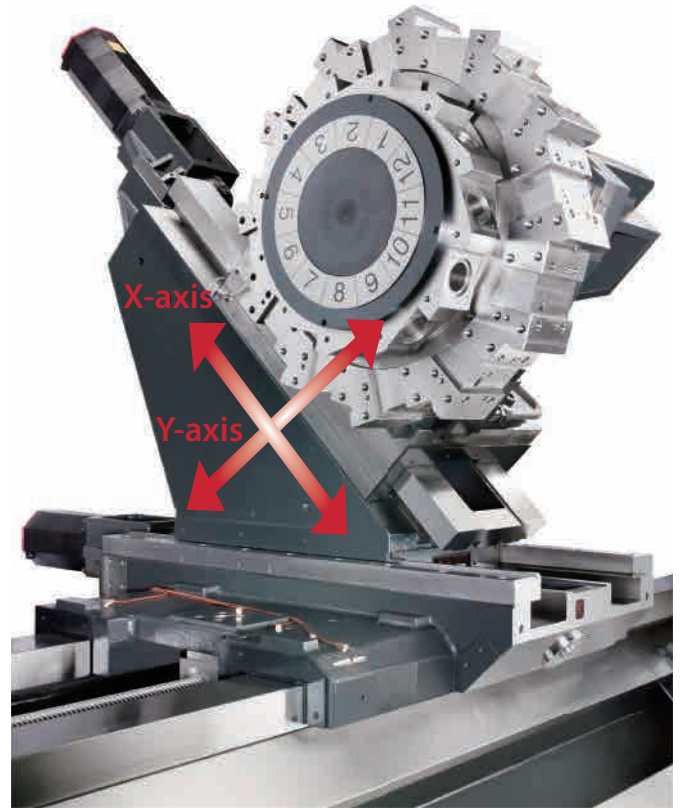

- ▶ Grooving with Y-axis control produces grooves with higher accuracy.



Work Range

[ 12-Stations Turret ]

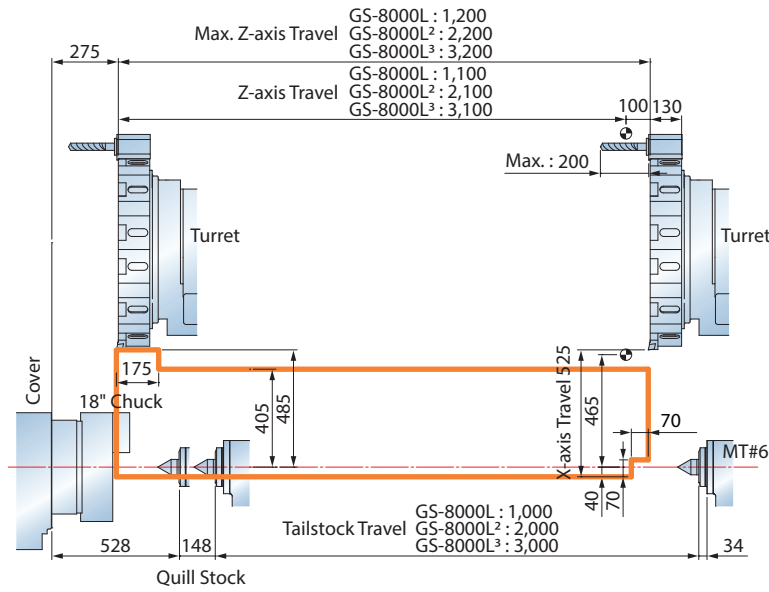

[ 12-Stations Live Tooling Turret ]

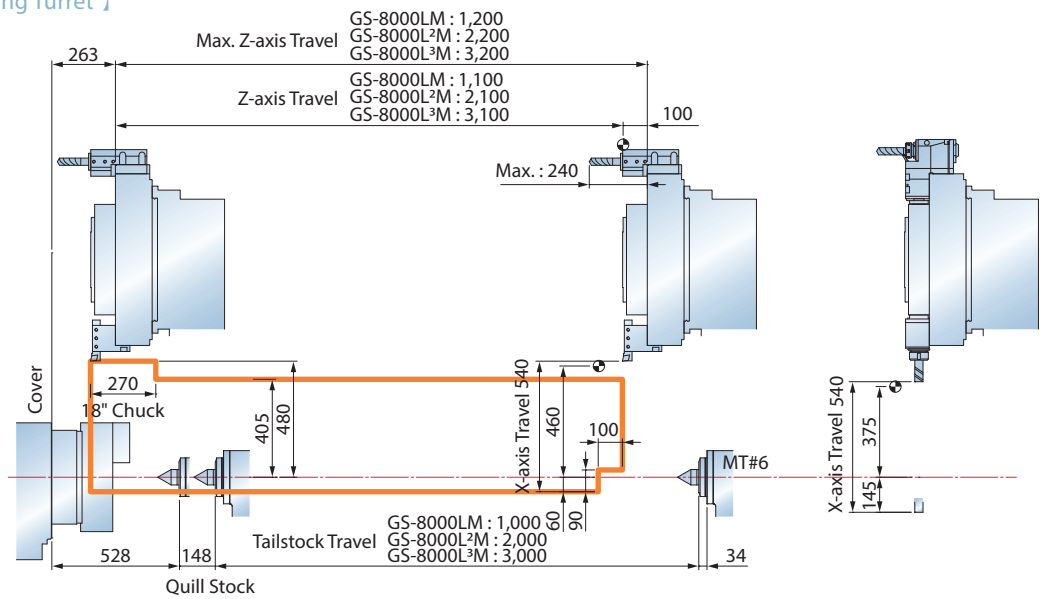

[ Y-axis ]

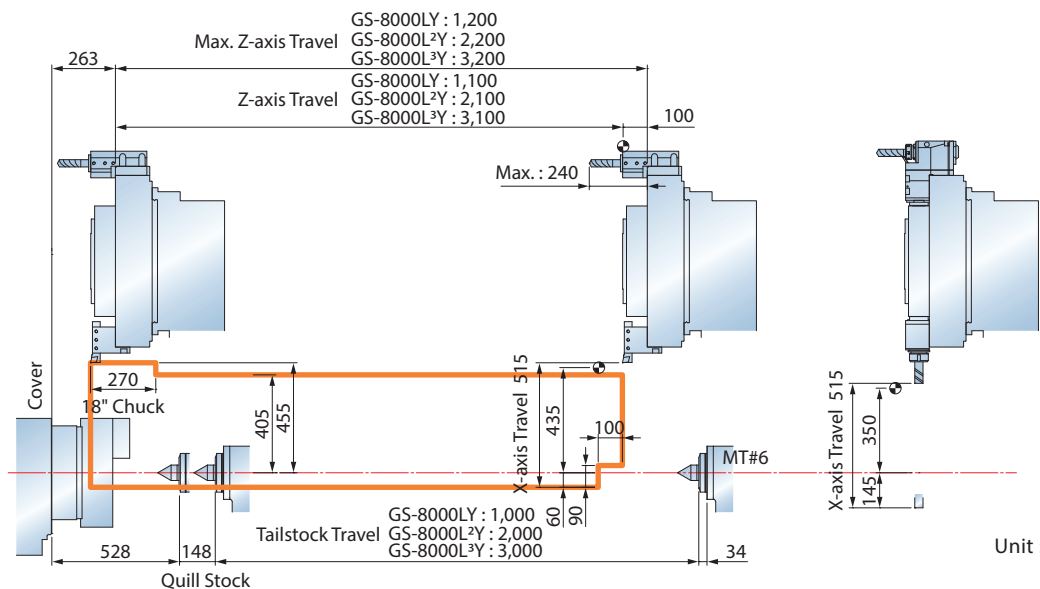

Unit : mm

## STANDARD &amp; OPTIONAL FEATURES

S : Standard    O : Option  
 - : Not available    C : Contact Goodway

		GS-8000
<b>SPINDLE</b>		
Main spindle configuration	3-Speed Gear	S
Rigid tapping & spindle orientation		S
Main spindle disk brake		O
Cs-axis & disk brake for main spindle*1		O
<b>WORK HOLDING</b>		
Hydraulic hollow cylinder for chuck	205 mm ID.	S
	21"	S
	24"***2	O
	32"***2	O
Hollow 3-jaws chuck & 1 set soft jaws	Air Chuck	O
Hard jaws		O
Special work holding chuck		C
In spindle work stopper		O
Spindle liner ( guide bushing )		O
Foot switch for chuck operation		S
Programmable base & quill hydraulic tailstock		S
MT#6 dead center quill		S
Foot switch for tailstock operation		O
Manual steady rest		O
Self-centering hydraulic steady rest		O
Foot switch for steady rest operation		O
Two-stage programmable pressur	Chuck clamping	O
	Tailstock thrust	O
<b>TURRET</b>		
12-station turret		S
12-station live tooling turret		O
Tool holder & sleeve package		S
Live tooling tool holders ( 0° x 2, 90° x 2 )*1		O
<b>MEASUREMENT</b>		
Renishaw HPRA tool presetter	Removeable	O
<b>COOLANT</b>		
Coolant pump	3 Kg/cm <sup>2</sup>	S
	5 Kg/cm <sup>2</sup>	O
High-pressure coolant system	20 Kg/cm <sup>2</sup>	C
Roll-out coolant tank		S
Oil skimmer		O
Coolant flow switch		O
Coolant level switch		O
Coolant intercooler system		O
<b>CHIP DISPOSAL</b>		
Chip conveyor with auto timer	Right discharge	S
Chip cart with coolant drain		O
Chuck air blow		O
Coolant gun		O
Oil mist collector		O
<b>AUTOMATIC OPERATION SUPPORT</b>		
Gantry-type loader / unloader		O
Auto door		O
External M-code output	4 sets ( 8 )	O
	8 sets ( 16 )	O
<b>SAFETY</b>		
Fully enclosed guarding		S
Door interlock ( incl. Mechanical lock )		S
Impact resistant viewing window		S
Tailstock stroke out - end check		S
Chuck cylinder stroke out - end check		S
Chuck cylinder check valve		S
Low hydraulic pressure detection switch		S
Over travel ( soft limit )		S
Load monitoring function		S

## OTHERS

		GS-8000
Tri-color machine status light tower		S
Work light		S
External work light		O
Electrical cabinet	Heat exchanger	S
	A/C cooling system	O
Complete hydraulic system		S
Advanced auto lubrication system		S
Foundation leveling & maintenance tool kit		S
Emergency maintenance electrical part package		S
Operation & maintenance manuals		S

## FANUC CONTROL FUNCTIONS

		Oi-TD	3i
PMC system	Oi-TD PMC : 25n sec/step	S	-
	3i PMC : 25n sec/step	-	S
Display	8.4" color LCD	S	-
	10.4" color LCD	O	S
Graphic function	Standard	S	S
	Dynamic	O	O
Full keypad	Small - 44 keys	S	-
	Large - 56 keys	O	S
Part program storage length	512 K bytes	S	-
	1 M bytes	-	S
	2 M bytes	-	O
	4 M bytes	-	O
	8 M bytes	-	O
	400	S	-
Registerable programs	1,000	-	S
	4,000	-	O
	64	S	-
Tool offset pairs	99	O	S
	400	-	O
	499	-	O
	999	-	O
	2000	-	O
Servo control	HRV2 ( 3 )	S	S
Conversational programming	Manual Guide Oi	S	-
	Manual Guide i*3	O	S
Servo motors	$\alpha$ i	S	S
Spindle motors	$\alpha$ i	S	S
Tool Life Management		S	S
Tool Nose Radius Compensation		S	S
Background editing		S	S
Variable Lead Thread Cutting		S	S
Polygon Turning		S	S*4
Unexpected disturbance torque detection function		S	S
Polar coordinate & cylindrical interpolation		-	O
Multiple Threading		S	S
Run hour & parts counter		S	S
Auto power off function		S	S
Custom macro B		S	S
RS-232 port		S	S
Memory card input /output		S	S
Ethernet ( 10 BASE )		S	S
Fast ethernet ( 100 BASE )		O	O

Specifications are subject to change without notice.

Above standard & optional features also apply to L models.

\*1 Standard on M ( live tooling ) models.

\*2 Tool setter must be deleted.

\*3 10.4" color LCD option needed.

\*4 For servo motor driven power turret only.

# MACHINE SPECIFICATIONS

CAPACITY		GS-8000L / L <sup>2</sup> / L <sup>3</sup>		
Max. swing diameter		Ø 1,030 mm		
Swing over saddle		Ø 810 mm		
Max. turning diameter		Ø 970 mm		
Max. turning length		1,200 / 2,200 / 3,200 mm		
Maximum weight of the work piece		5,000 Kg		
Chuck size		18" ( Opt. 24" )		
SPINDLE				
Hole through spindle		<b>A</b> Ø 205	<b>B</b> Ø 260	<b>C</b> Ø 320 mm
Spindle bearing diameter		<b>A</b> Ø 260	<b>B</b> Ø 340	<b>C</b> Ø 400 mm
Spindle nose		<b>A</b> A2-15	<b>B</b> A2-15	<b>C</b> A2-20
Motor output ( cont. / 15 min. )		30 / 45 kW		
Motor full output speed		1,150 rpm		
Spindle drive system		3-Speed Gear		
Spindle speed		<b>A</b> 5 ~ 1,100	<b>B</b> 5 ~ 800	<b>C</b> 5 ~ 700 rpm
Spindle full output speed	<b>A</b>	Low speed : 86	Medium speed : 142	High speed : 215 rpm
	<b>B</b>	Low speed : 60	Medium speed : 100	High speed : 155 rpm
	<b>C</b>	Low speed : 58	Medium speed : 95	High speed : 145 rpm
Spindle torque ( cont. )	<b>A</b>	Low speed : 3,320	Medium speed : 2,010	High speed : 1,325 N-m
	<b>B</b>	Low speed : 4,605	Medium speed : 2,790	High speed : 1,840 N-m
	<b>C</b>	Low speed : 4,950	Medium speed : 3,000	High speed : 1,980 N-m
Spindle torque ( 15 min. )	<b>A</b>	Low speed : 4,915	Medium speed : 2,975	High speed : 1,965 N-m
	<b>B</b>	Low speed : 6,815	Medium speed : 4,130	High speed : 2,720 N-m
	<b>C</b>	Low speed : 7,330	Medium speed : 4,440	High speed : 2,930 N-m
Cf-AXIS ( OPT. )				
Cf-axis drive motor		AC 3.0 kW		
Cf-axis rapids		<b>A</b> 20 rpm	<b>B</b> 28 rpm	<b>C</b> 28 rpm
Cf-axis torque output ( cont. )		<b>A</b> 1,296 N-m	<b>B</b> 1,800 N-m	<b>C</b> 1,800 N-m
X & Z AXES				
Max. X-axis travel		525 mm		
Max. Z-axis travel		1,200 / 2,200 / 3,200 mm		
X / Z axes rapids		10.5 / 12 m/min.		
Slide way type		Box Way		
Feed rates		1~ 4,800 mm/min.		
X / Z axes servo motor		AC 6 kW / AC 7 kW		
X / Z axes ball screw diameter		Ø 45 / 63 mm		
X / Z axes thrust ( cont. )		3,047 / 3,204 Kg		
TURRET				
Stations		12		
Indexing drive		Servo motor		
Indexing speed		0.5 sec. ( Adjacent ) / 1.5 sec. ( 180° Single step )		
O.D. tool shank size		□ 32 mm		
I.D. tool shank size		Ø 60 mm		

<b>LIVE TOOLING TURRET ( OPT. )</b>		<b>GS-8000L / L<sup>2</sup> / L<sup>3</sup></b>
Max. turning diameter		Ø 960 mm
Live tooling stations		12
Live tooling motor output ( cont. / 30 min. )		AC 7.5 / 9 kW
Indexing drive type		FANUC AC spindle motor
Indexing speed		0.5 sec. ( adjacent ) / 1.5 sec. ( 180° Single step )
O.D. / I.D. tool shank size		□ 32 mm / Ø 60 mm
Live tooling shank size		0° : ER 50 / 90° : ER 40
Live tooling RPM range		3,000 rpm
<b>Y-AXIS ( OPT. )</b>		
Swing over saddle		Ø 720 mm
Max. turning diameter		Ø 910 mm
Max. X / Z axes travel		515 / ± 160 mm
Y-axis rapids		16 m/min.
Y-axis servo motor		AC 7 kW
Y-axis ball screw diameter		Ø 45 mm
Y-axis thrust ( cont. )		1,602 Kgf
<b>TAILSTOCK</b>		
Quill center taper		MT#6 ( Dead center )
Quill diameter / travel		Ø 160 mm / 150 mm
Tailstock base travel		1,000 / 2,000 / 3,000 mm
Programmable quill / base		Yes / Yes
<b>GENERAL</b>		
CNC controller		FANUC Oi-TD ( Opt. 31i )
Voltage / Power requirement		AC 220 V / 80 KVA
Hydraulic tank capacity		40 L
Coolant tank capacity		590 L
Coolant pump		0.5 kW ( 0.75 HP , 60 Hz ) rated at 3 bar ( 44 PSI )
Machine weight		13,700 / 15,500 / 17,300 Kg
Dimensions L × W × H		5,650 × 3,150 × 3,060 / 6,650 × 3,150 × 3,060 / 7,650 × 3,150 × 3,060 mm

Specifications are subject to change without notice.

### Machine Layout

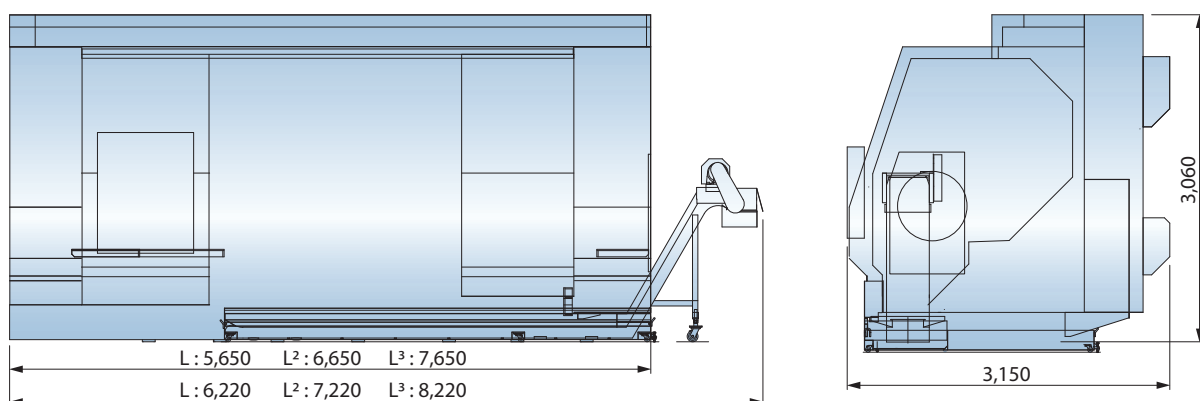

Unit : mm



## **GOODWAY MACHINE CORP.**

---

### **Headquarters**

No.13, 5<sup>th</sup> Road,  
Taichung Industrial Park,  
Taichung City, 407, Taiwan, R.O.C.  
Website : [www.goodwaycnc.com](http://www.goodwaycnc.com)  
E-mail : [goodway@goodwaycnc.com](mailto:goodway@goodwaycnc.com)

### **Central Taiwan Science Park Branch**

No. 38, Keyuan Road,  
Central Taiwan Science Park.Taichung,  
Taichung City, 407, Taiwan, R.O.C.  
TEL : + 886-4-2463-6000  
FAX : + 886-4-2463-9600

## **GOODWAY (SUZHOU) MACHINE CORP.**

---

No.589, Chengyang Road,  
Xiang Cheng Economic Development District  
Suzhou City, Jiangsu, China  
TEL : + 86-512-6576-3699  
FAX : + 86-512-6576-7299  
E-mail : [goodway.suzhou@goodwaycnc.com.tw](mailto:goodway.suzhou@goodwaycnc.com.tw)