

Ultra High Performance Vertical Machining Center

# NSV 102A

*Introducing the new NSV series, ultra fast vertical machining center for high speed machining needs. The NSV series provides superb axial and radial cutting rigidity, high performance in high speed and high chip removal rate, would be the best machine to help the inventors increase the manufacturing efficiency and benefit.*



Cutting Demo



- **1g** Axial Acceleration
- **60/60/48m/min.** Rapid Feedrate
- **30T (48/60T)** Tools Capacity
- **IDD 15,000rpm** Max. Spindle Speed
- **1,020/600/600mm** X/Y/Z Travel
- **400/850/500mm**  
X/Y/Z Extra Large Span of Guideways
- **All Roller Type Linear Motion Guides**

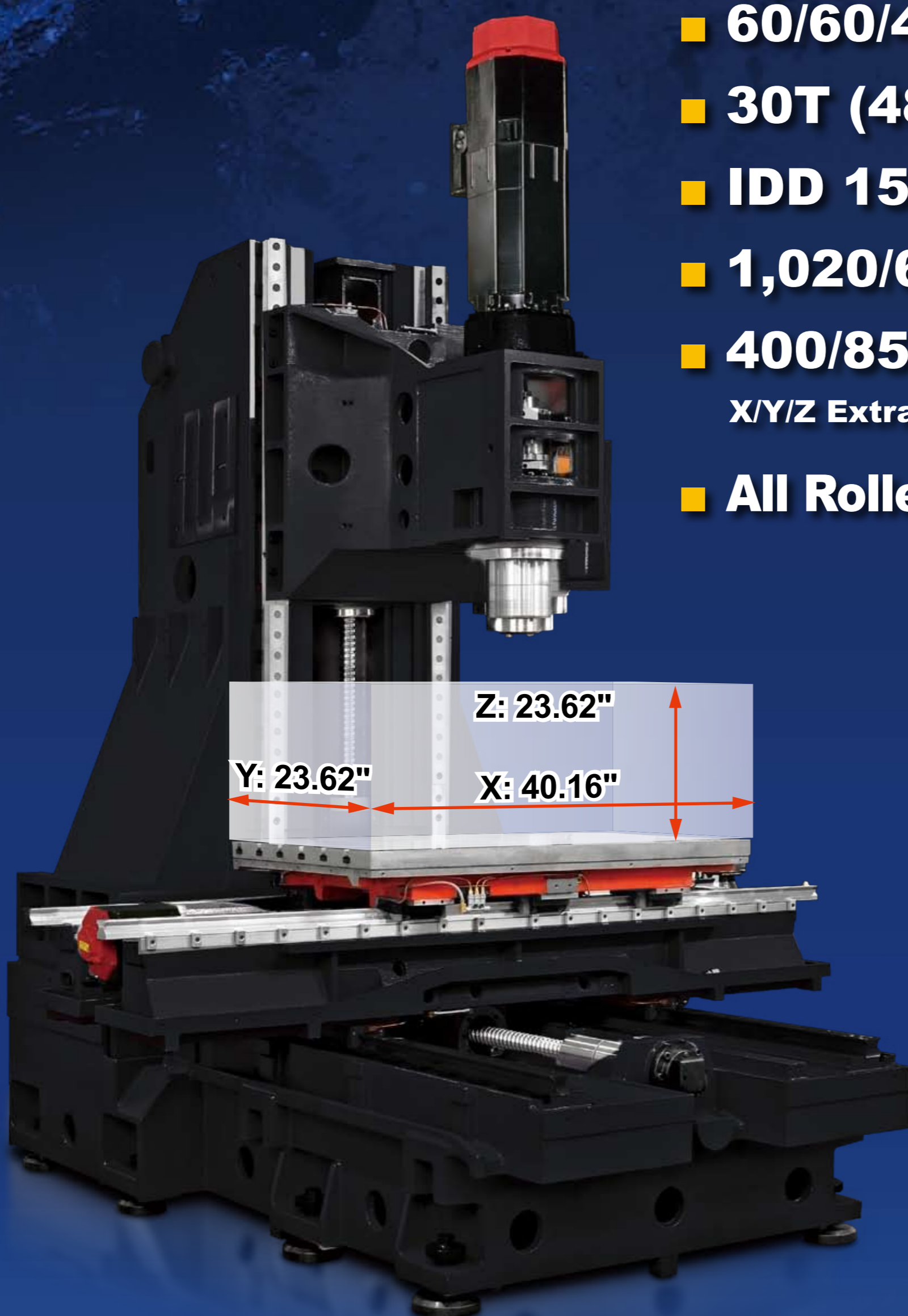

- **Doble tuerca Embalada**



# YCM<sup>®</sup>

[www.YCMCNC.com](http://www.YCMCNC.com)