

SUPER GV SERIES

SUPER SIZED CNC VERTICAL TURNING CENTER



GV

GOODWAY VERTICAL TURNING CENTERS

TRUSTWORTHY MACHINES GO BEYOND EXPECTATIONS

With 40 years of trust and faith from each of our customers, you can now hold on to the present and future by experiencing Goodway's latest state-of-the-art vertical turning center.

The all new SUPER GV series, gives you more than you can imagine.



Max. Turning Length

Max. Turning Diameter

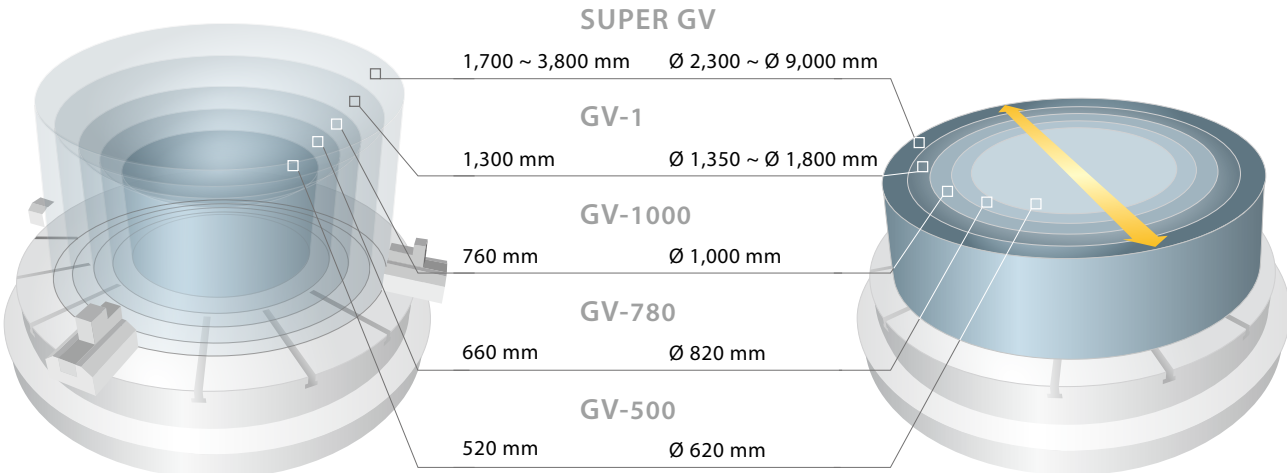

SUPER SIZED CNC VERTICAL TURNING CENTER

With leading technologies and high quality components, the SUPER GV CNC vertical turning center combines heavy-duty, high rigidity and super large machining range advantages to provide you with large sized, asymmetric work piece turning capabilities. The optimal reinforced structure of these series can maintain long term precision even if the table diameter is reached up to 8,000mm. Plus, with the optional dual ram or live tooling spindle and C-axis, all kinds of complex turning applications can be done easily, which can meet your needs for today and tomorrow.

Super Large Turning Range

Maximum turning diameter can reach up to \varnothing 9,000 mm ; maximum work piece weight can reach up to 300,000 Kg (GV-8000 series).

High Rigidity Structure

The bed, column and bridge casting components are of Meehanite casting with a symmetric structure design, which ensures optimal thermal balance and heavy duty rigidity.

Powerful High Torque Motors

The work piece and live tooling spindles uses a high power 2-speed heavy-duty gear box motor to provide ample torque output for heavy duty cutting applications.

High Efficiency Chip Removal System

The standard chip wash down coolant system can flush away great amount of chips into the coolant tank, and are sent outside from the machine through the chip conveyor; this tremendously improves the machine's overall accuracy by lowering thermal expansion effects to a minimum.

Turning, Milling And Grinding Multi-Tasking Capability

The optional live tooling spindle provides turning, milling, grinding, drilling, and tapping capabilities, which greatly increases production efficiency while saving equipment investment costs.



(GV-2500M model shown.)



HIGH RIGIDITY CONSTRUCTION

- By using Finite Element Methods (FEM), optimal reinforce ribbings are directly cast into the bed and column structure. Mechanical rigidity has been increased by more than 30% when compared to conventional designs. The SUPER GV series is capable of performing super heavy-duty turning and maintain long-term super high-precision accuracy.
- The heavily ribbed, symmetric box-type designed bed, column and cross beam are of Meehanite casting. This high rigidity structure can effectively reduce thermal distortion while increasing heavy-duty cutting capability and maintaining machining accuracy.



(Casting structure of GV-2500M series model shown.)

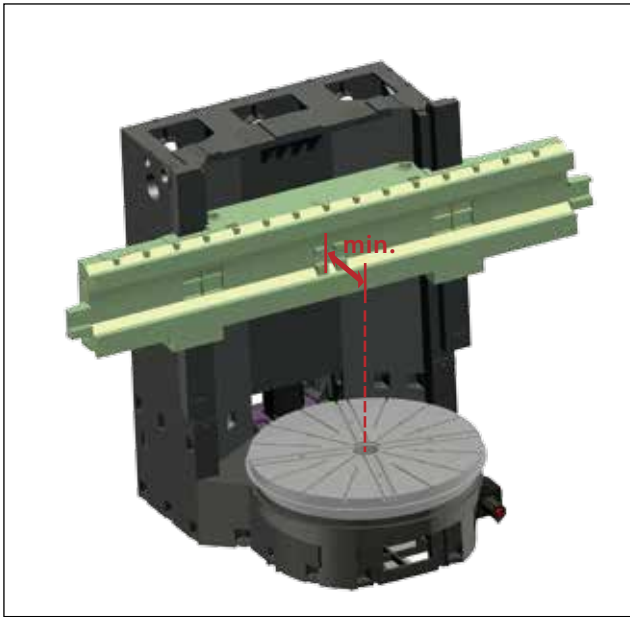

■ **One-piece Column & Bridge Structure**
(GV-2000 ~ GV-2500)

The one-piece column & bridge is firmly mounted on top of the bed, which ensures machine overall rigidity and minimizes spindle over hang to provide optimal machining accuracy.

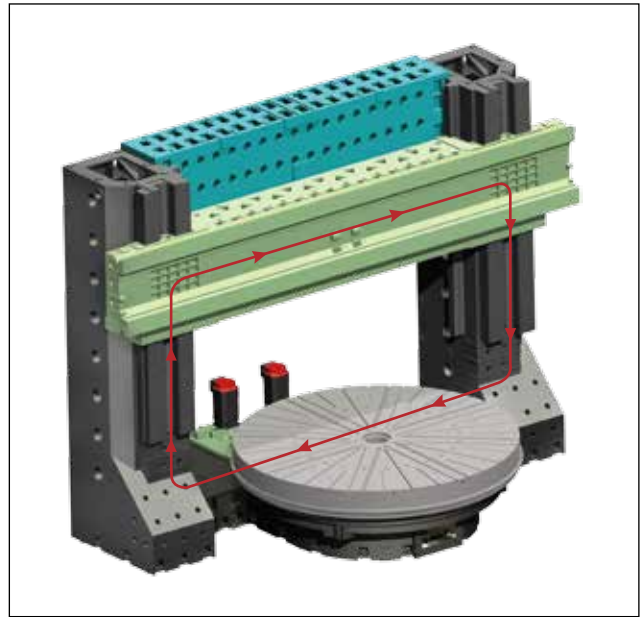

■ **Bridge Type Structure**
(GV-3000 ~ GV-8000)

The super rigid construction of the base and bed, double column, and cross beam, can easily fulfill heavy load and cutting requirements.



Super large box way and components are of one-piece casting; they are applied with heat treatment and precision grinded to provide maximum strength and accuracy.



Contact surfaces of all slides, spindles, ball screw bearing housings, bed and column are precision hand scraped to provide maximum assembly precision, structural rigidity, and load distribution.



The optional high resolution close-loop linear scale ensure optimal positioning and repeatability accuracy.



TOOLING SPINDLE

- The square ram on the tooling spindle is adopted with a closed-type design and fixed with powerful wedges. This gives the SUPER GV series with greater structural rigidity and machining accuracy compared to peer models with a semi-closed type square ram structure.

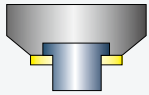

Semi-closed Type Square Ram

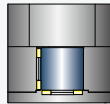

Closed-type Square Ram



Ram Dimension

Unit : mm

Model	GV-2000	GV-2500	GV-3000	GV-3500	GV-4000
A	220	250	300 / 350 (OPT.)		

Model	GV-5000	GV-6000	GV-7000	GV-8000
A	350 / 400 (OPT.)			

Dual Ram Structure

- With the optional dual ram structure, multiple machining applications (such as rough turning / fine turning or drilling / tapping / milling) can be operated at the same time; one machine can replace two vertical turning centers which saves tool change time and increases floor space usage.



Diversed Machining Mode

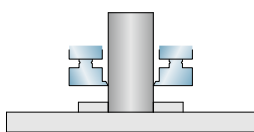

Dual Simultaneous Turning
Increases machining efficiency

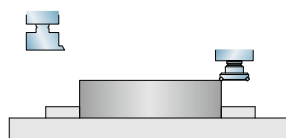

Optional Single Live Tooling Spindle
Reduces Tool Change Time

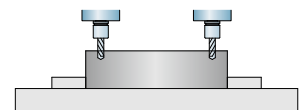

Optional Double Live Tooling Spindle
Reduces Tool Change Time

Live Tooling Spindle

- The live tooling spindle uses Japan NN Type roller bearings to provide high rigidity, high precision, and long life span advantages.
- The high reduction ratio 2-speed gear box uses high hardness Nickel-Chromium-Molybdenum alloy with forced oil-feed for lubrication and coolant; the gear box can maintain normal operation and low wear even under long hours of low-speed, high-torque working conditions.

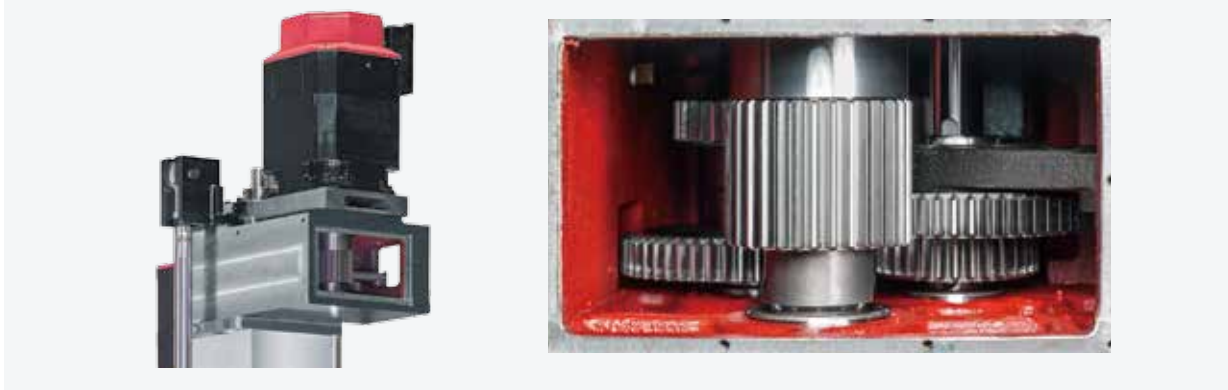

Live Tooling Spindle Output

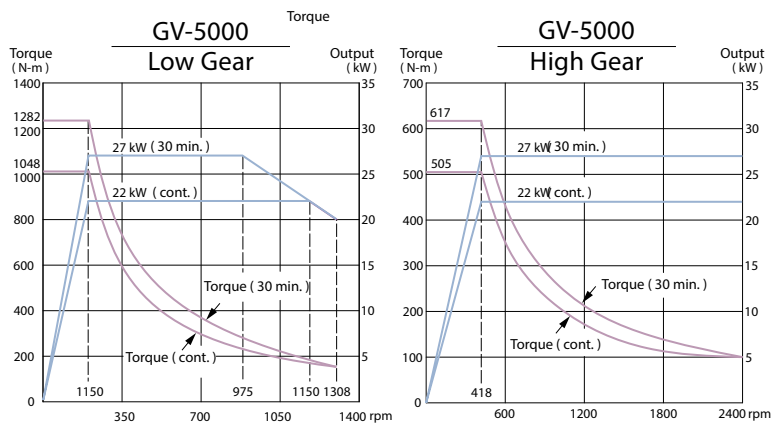
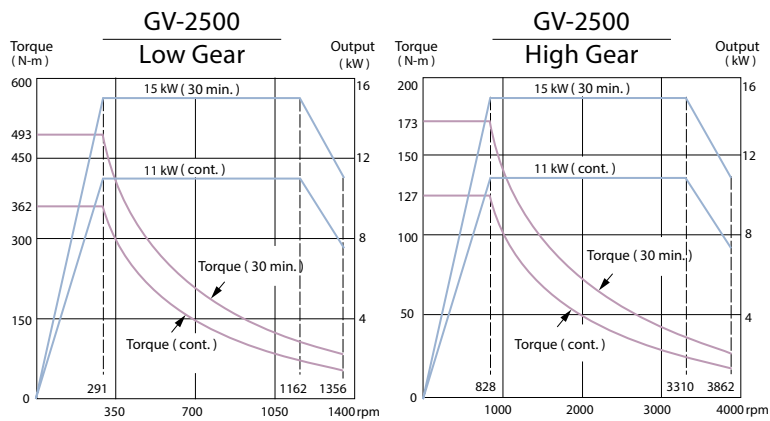

WORK-PIECE SPINDLE

- The work piece spindle uses high power 2-speed gear box motor which provides 74,140 N-m torque output under low speed (GV-2500); various large sized work pieces can be overcome easily.
- The high reduction ratio 2-speed gear box uses high hardness Nickel-Chromium-Molybdenum alloy with forced oil-feed for lubrication and coolant; the gear box can maintain optimal performance with long life span.

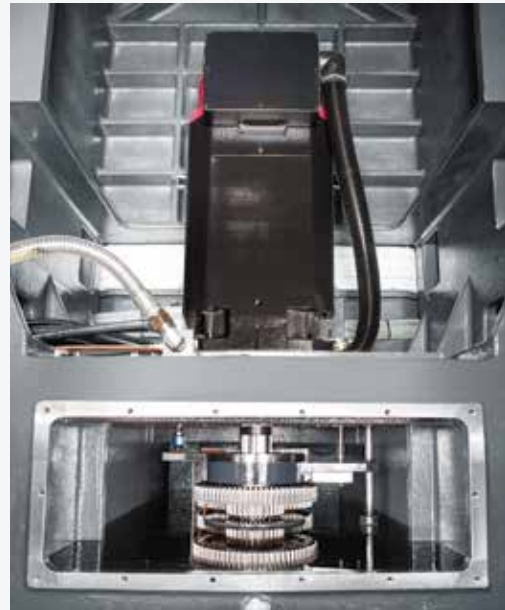

Bearing Configuration

Model	GV-2000	GV-2500	GV-3000	GV-3500	GV-4000	GV-5000	GV-6000	GV-7000	GV-8000
Cross Roller Bearings	S	S	S	S	S	—	—	—	—
Hydrostatic Bearings	—	—	O	O	O	S	S	S	S

S : Standard O : Option — : Not available

Cross Roller Bearings

- The high rigidity high precision cross roller bearings can sustain high radial, axial and torque load, which greatly reduces deformation and thermal errors while increasing the rotary table's rotational accuracy and load capacity when working on heavy work-pieces.



Work-Piece Spindle Output

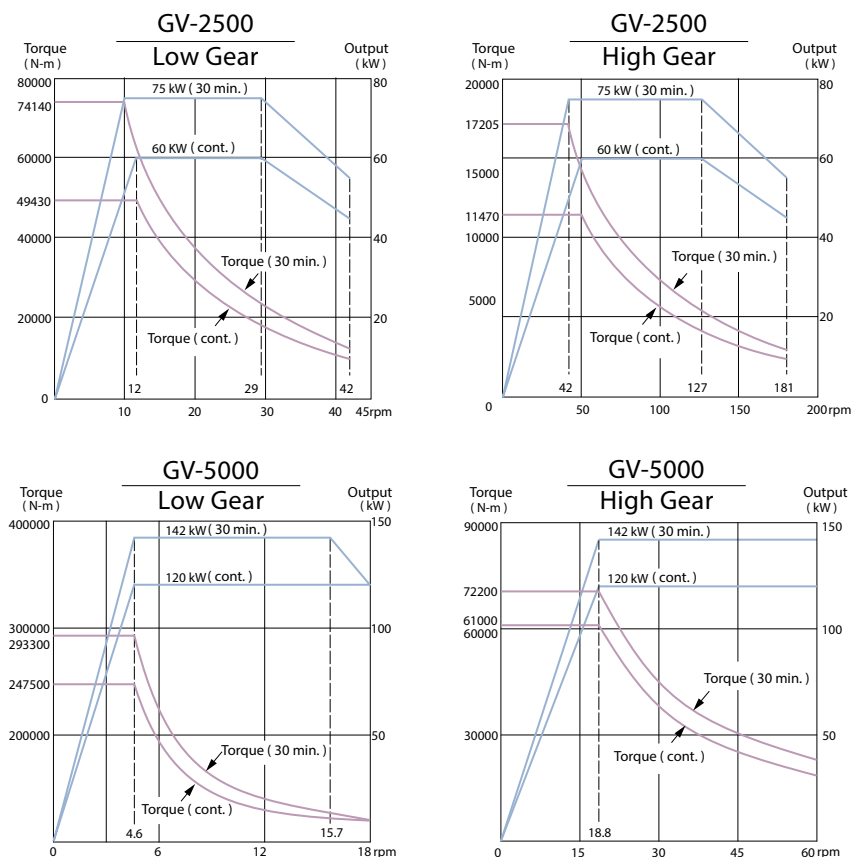



Hydrostatic Bearings

- The high rigidity hydrostatic bearings provide absolute zero static friction coefficient and low kinetic friction coefficient which can easily drive the rotary table without needing high torque output. Plus the stick-slip effect is eliminated under low speed which provides stable and smooth rotating movement while maintaining maximum dynamic accuracy.
- The hydrostatic bearings provides great damping in vertical movement and low damping in horizontal movement. The oil film damper provides outstanding dynamic rigidity.

Spindle Accuracy Comparison

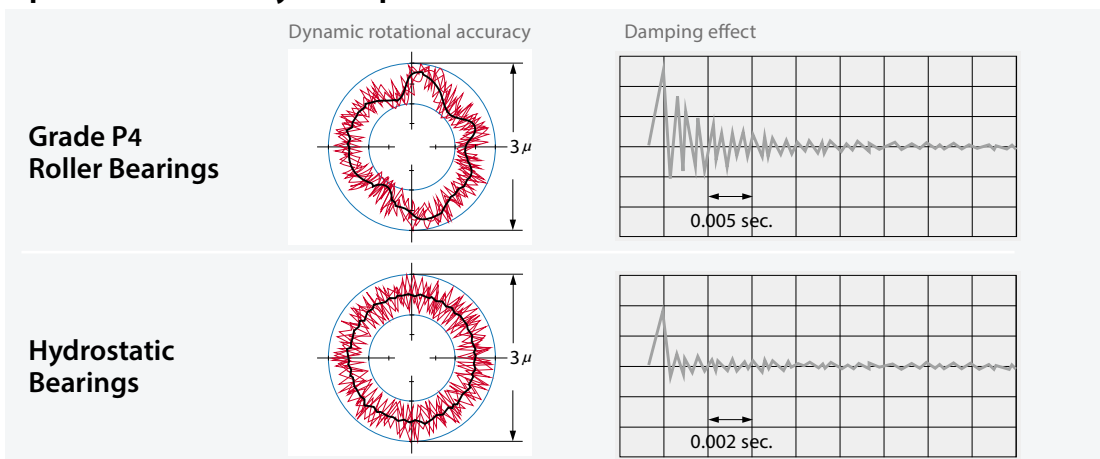

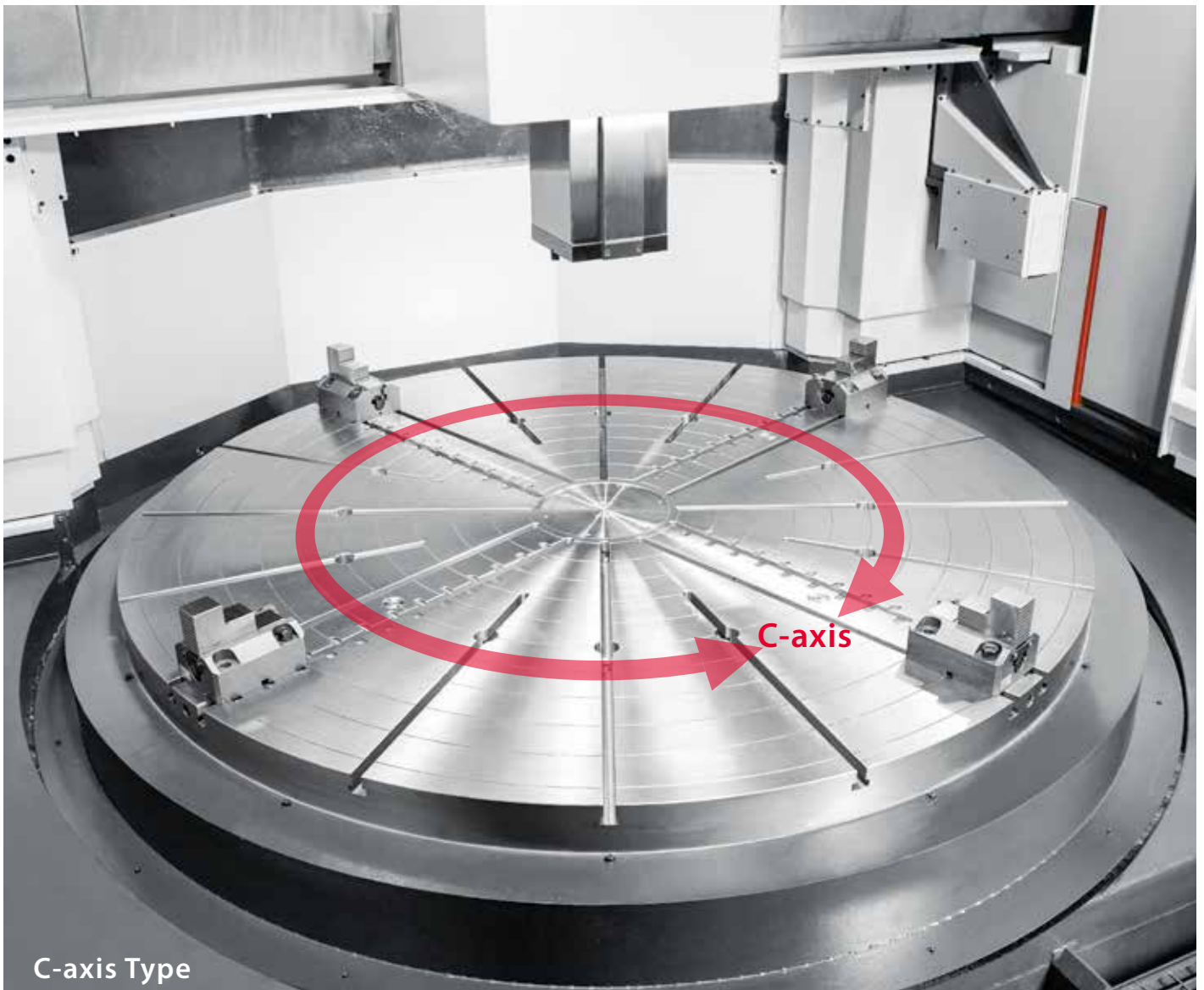

C-axis Type

Model	GV-2000	GV-2500	GV-3000	GV-3500	GV-4000	GV-5000	GV-6000	GV-7000	GV-8000
Type	Cf	Cf	Cs	Cs	Cs	Cs	Cs	Cs	Cs

HIGH RIGIDITY C-axis

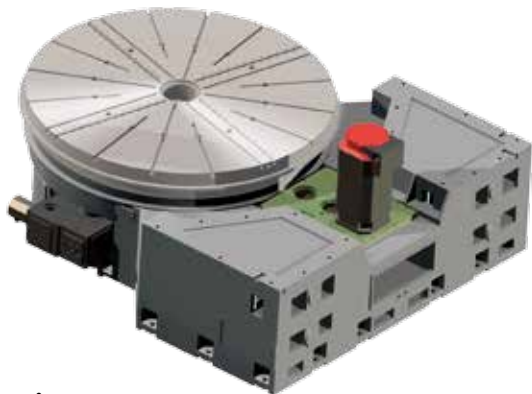

Cf-axis

The Cf-axis and disk brake system provides the most rigid and powerful type of C-axis in the market today. The surface accuracy and dynamic accuracy can be maintained under heavy duty cutting conditions.

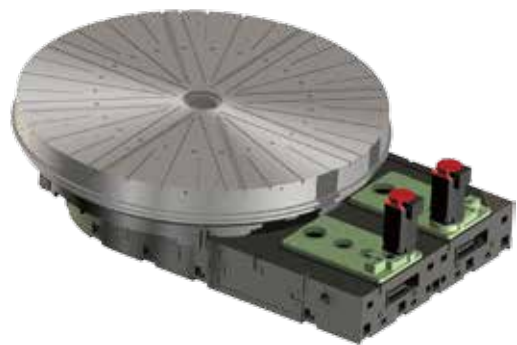

Cs-axis

The Cs-axis is driven by double spindle motors which eliminates gear backlash while providing double torque output. The repeatability can reach up to $\pm 5''$ and positioning accuracy can reach up to $\pm 7.5''$ under normal working conditions.

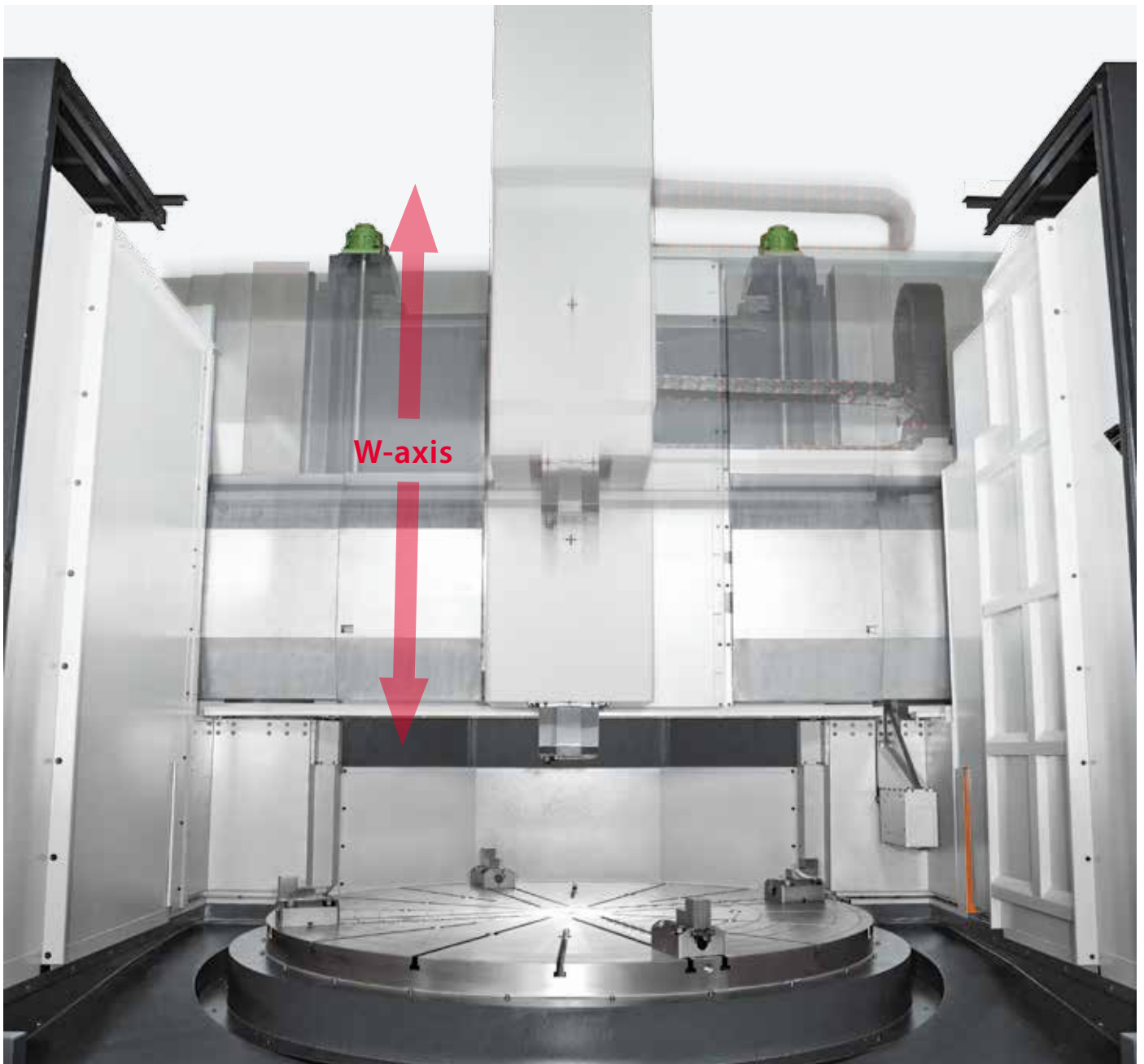

MOVING CROSS RAIL STRUCTURE

- The moving cross rail structure is installed with a set of symmetric ball screws which is driven by servo motors to provide high precision and heavy load axial feed capability.
- The structure uses two sets of live locking bolts to support the cross beam. After precision positioning, the bolts will be locked by a hydraulic clamping force to ensure the overall rigidity.
- The space between each step of the positioning mechanism is 200 mm which can easily fulfill various types of machining requirements.

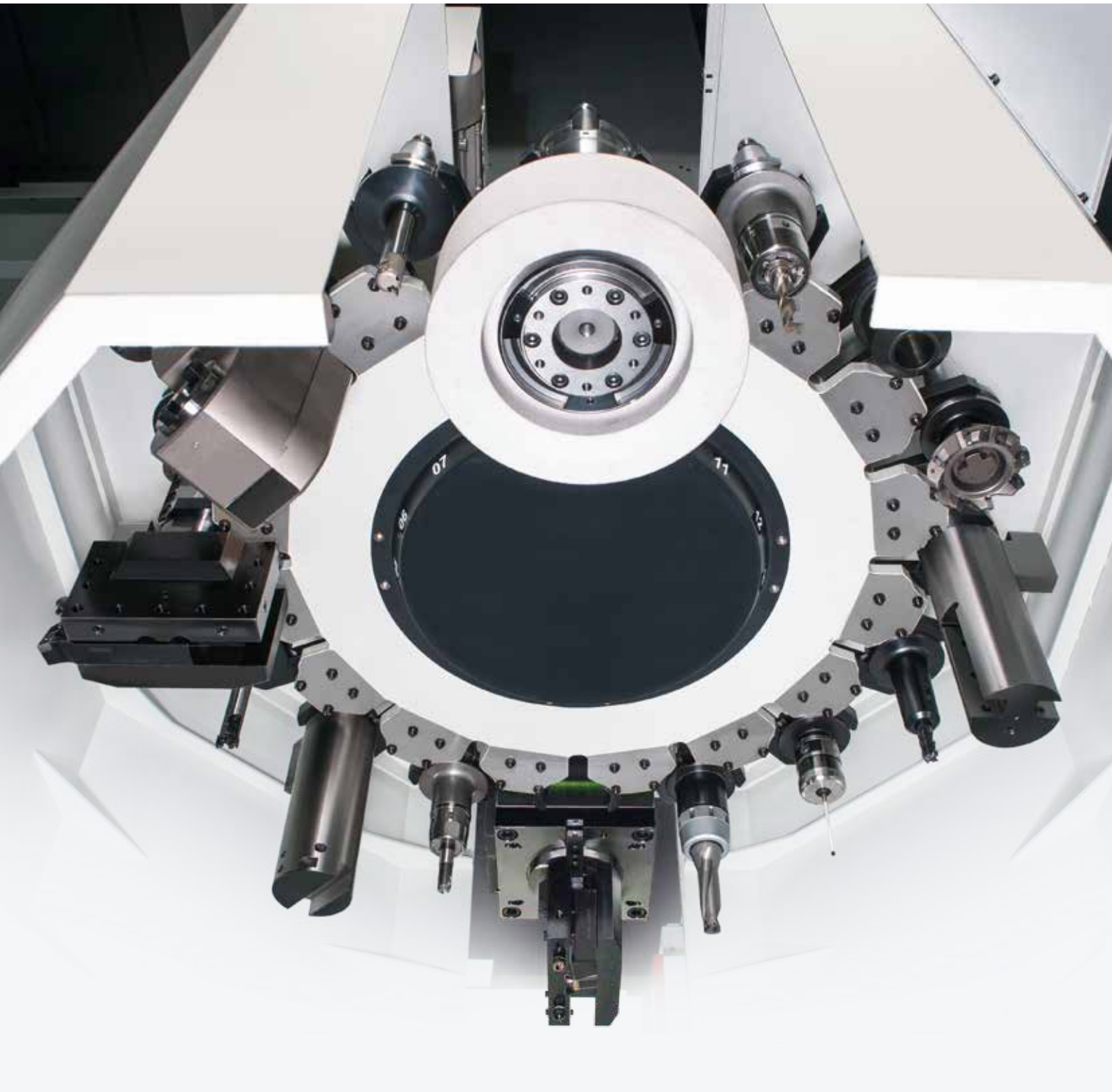

ATC SYSTEM

- Standard 16-tool umbrella type magazine is designed with cam movement mechanism which provides bi-directional tool selection, low noise and accurate positioning advantages.
- The optional 24-tool umbrella type magazine provides ample amount of tools which can easily fulfill complex work-pieces machining applications.

STANDARD & OPTIONAL FEATURES

S : Standard O : Option
 - : Not available C : Contact Goodway

		SUPER GV
WORK-PIECE SPINDLE		
Main spindle		S
Rigid tapping		S
C-axis		O
Disk brake for C-axis		O
Lubrication system		S
WORK-PIECE HOLDING		
4-jaw manual table		S
TOOLING SPINDLE		
BT50		S
BT60 (GV-3000 and above)		O
Spindle coolant		O
Coolant through spindle (CTS)		S
Milling functions		O
Gear box lubrication system		O
Umbrella type ATC magazine	16 T	S
	24 T	O
Chain type ATC magazine (milling functions)	24 T	C
	32 T	C
MEASUREMENT		
Tool presetter		O
Part presence check		O
X & Z axes linear scales		O
COOLANT		
Coolant pump	5 Kg/cm ²	S
High-pressure coolant system	20 Kg/cm ²	O
Oil skimmer		O
Coolant flow switch		O
Coolant level switch		O
Coolant intercooler system		O
Paper Tape Filter		O
CHIP DISPOSAL		
Chip conveyor with auto timer		O
Chip cart		O
Coolant gun		O
Air gun		O
SAFETY		
Fully enclosed splash guard without roof		S
Fully enclosed splash guard with roof		O
Door interlock (incl. Mechanical lock)		S
Impact resistant viewing window		S
Low hydraulic pressure detection switch		S
Over travel (soft limit)		S
Load monitoring function		S
OTHERS		
Tri-color operation status signal light tower		S
Florescent work light		S
Electrical cabinet	Heat exchanger	S
	A/C cooling system	O
Complete hydraulic system		S
Advanced auto lubrication system		S
Emergency maintenance electrical part package		S
Operation & maintenance manuals		S

		8400 SI		
SIEMENS CONTROL FUNCTIONS				
SYSTEM CONFIGURATION	CNC User Memory	3M	S	
		9M	O	
		15M	O	
	10.4" LCD display		S	
AXIS FUNCTION	Separate feed for corners & chamfers		S	
SPINDLE FUNCTION	Oriented spindle stop		S	
	Constant cutting speed		S	
	Constant thread pitch cutting		S	
	Variable thread pitch cutting		S	
	Multiple thread cutting		S	
	Rigid tapping		S	
INTERPOLATION / COUPLING	3D Circular interpolation		S	
	Helical interpolation (2D+2)		S	
	NURBS interpolation		S	
	Polynomial interpolation		O	
	Involute interpolation		O	
	Machining on end face		O	
	Multi-edge / Polygon turning		O	
HSC	Look ahead block	150	S	
		250	O	
		500	O	
OPERATION MODE	Metric / Inch switchover (JOG Mode)		S	
CNC PROGRAMMING LANGUAGE	Global program variables		S	
	Global / local user variables		S	
	Macro technique		S	
	Part programs on NCU, max	1,000	S	
	Workpieces on NCU, max	250	S	
	Part programs on CF card (PCU50)		S	
	Part programs on USB device		S	
	Part programs on network dirve		S	
	Read / Write system variables		S	
	Animate cycle support (program GUIDE)		S	
PROGRAMMING SUPPORT	Animate machining step support (Shop Turn)		S	
	Customer cycles dialog support		S	
	Geometry processor for contour		S	
	Basic Drill / Mill technology cycles		S	
	Basic Truning technology cycles		S	
	Free contour pocketing (with island)		S	
	DXF contour conveter (CAD Reader)		O	
	2D simulation (finished part)		S	
	3D simulation 1 (finished part)		O	
	WORK OFFSET	Number of basic frames , max	16	S
100			S	
Zero / work offsets, programmable				S
TOOL	Operaton with tool management		S	
	Monitor of tool life and part count		S	
	3D tool radius compensation		S	
	Fast Ethernet Ports		S	
COMMUNICATIONS	Network drives, FTP , max	8	S	
		External PROFINET network		S
		Remote control system (local network)		S
		Remote control system (internet)		O
SPECIAL FUNCTIONS	Auto servo turning		S	
	Remote Diagnose via Ethernet		S	



GENERAL DIMENSION

Unit : mm

Turning Tool Holder

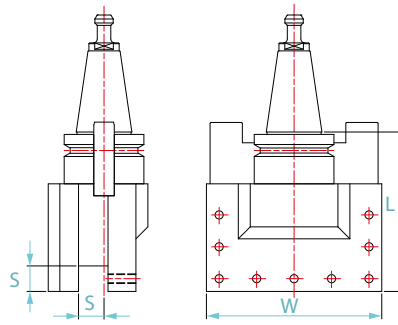

Taper	W	L	S
BT50	220	200	32
BT50	220	210	40
BT50	250	200	32
BT50	250	210	40
BT50	270	200	32
BT50	270	210	40
BT60	340	250	32
BT60	340	260	40

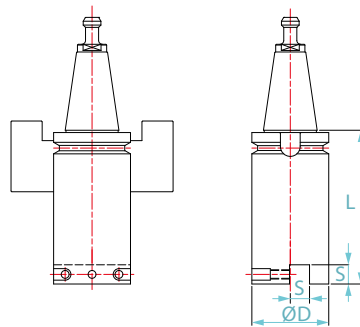

Taper	L	S	D
BT50	200	25	100
BT50	300	25	100
BT60	200	25	140
BT60	300	25	140

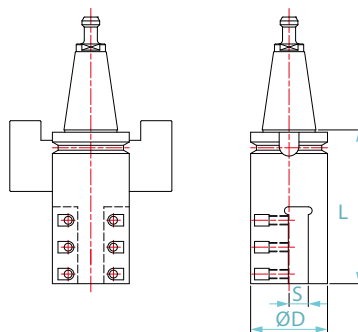

Taper	L	S	D
BT50	200	25	100
BT50	300	25	100
BT60	200	25	140
BT60	300	25	140

Milling Tool Holder

BT50

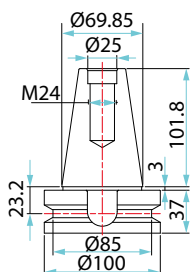
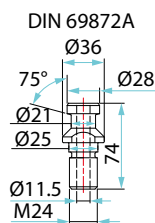

BT60

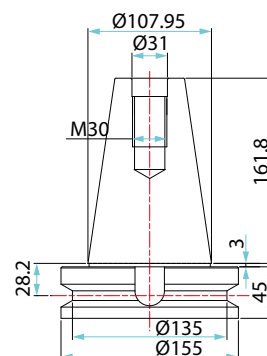
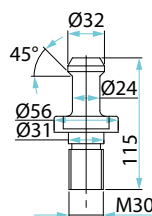

Tool Shank (Optional)

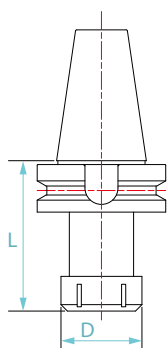

Tapping Tool Holders

Taper	L	D	Tapping Range
BT50-TER16	80	28	M3-M12
BT50-TER40	117	63	M12-M35
BT60-TER16	83	28	M3-M12
BT60-TER40	126	63	M12-M35

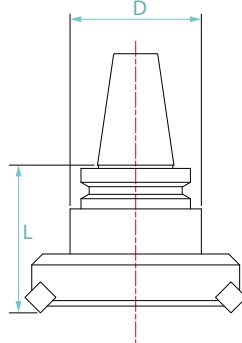

Face Milling Tool Holders

Taper	L	D	Cutter Dia.
BT50-FMA25.4-105	125	85	80
BT50-FMA31.75-105	127	85	100
BT50-FMA38.1-75	98	95	125
BT50-FMA50.8-75	99	95	150
BT60-FMA25.4-105	125	85	80
BT60-FMA31.75-105	127	85	100
BT60-FMA38.1-75	98	95	125
BT60-FMA50.8-75	99	95	150

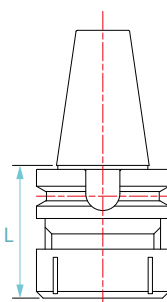

Drilling (Collect Type) Tool Holders

Taper	L	Capacity	Collet Type
BT50-ER20-100	100	1-13	ER20
BT50-ER32-100	100	2-20	ER32
BT50-ER40-100	100	3-26	ER40
BT60-ER20-100	100	1-13	ER20
BT60-ER32-100	100	2-20	ER32
BT60-ER40-100	100	3-26	ER40

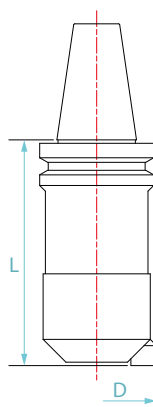

Boring Tool Holders

Taper	L	D
BT50-BSA62-300	300	62 ~ 90
BT50-BSA72-320	320	72 ~ 110
BT50-BSA105-195	195	105 ~ 160
BT60-BSA62-300	300	62 ~ 90
BT60-BSA72-320	320	72 ~ 110
BT60-BSA105-195	195	105 ~ 160

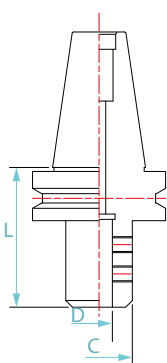

Drilling (Side Lock) Tool Holders

Taper	L	C	D
BT50-SLA20-105	105	50	20
BT50-SLA25-105	105	55	25
BT50-SLA32-105	105	60	32
BT50-SLA40-105	105	80	40
BT50-SLA50.8-105	105	95	50.8
BT60-SLA20-105	105	50	20
BT60-SLA25-105	105	55	25
BT60-SLA32-105	105	60	32
BT60-SLA40-105	105	80	40
BT60-SLA50.8-105	105	95	50.8

GENERAL DIMENSION

Unit : mm

Tooling System

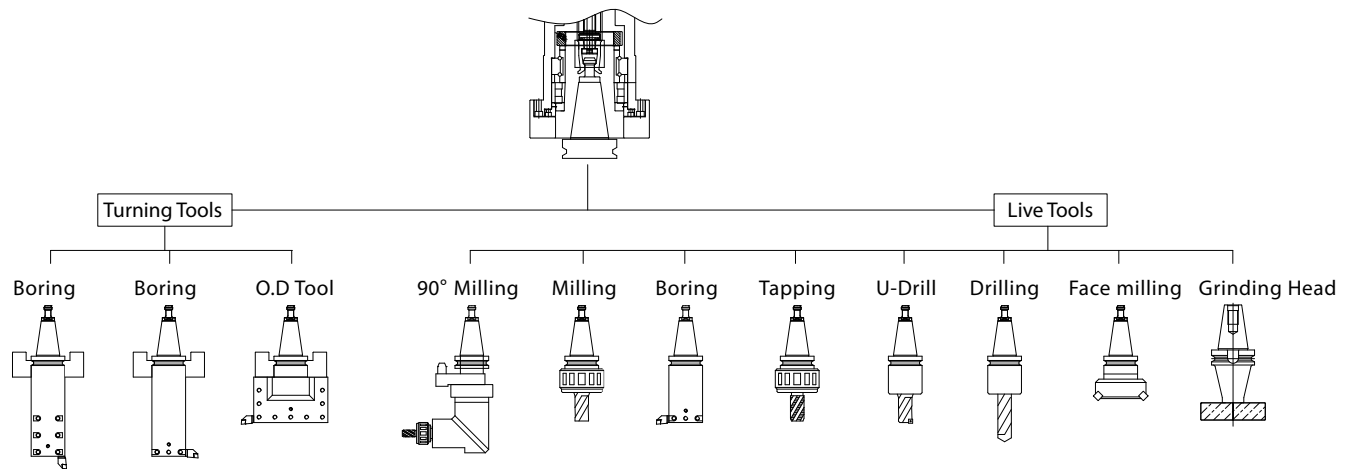

X-axis Travel

Single Ram (1R series)

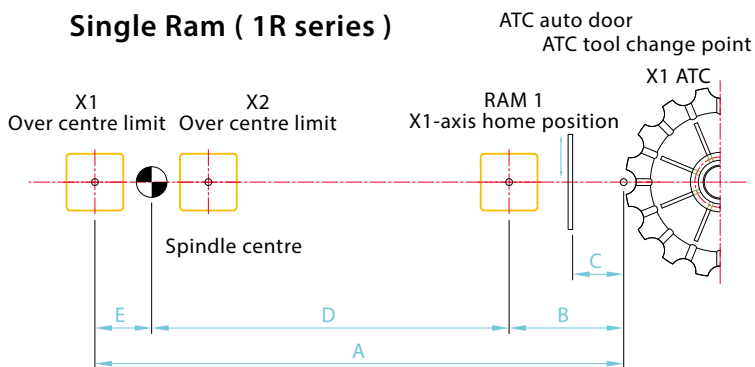

Model	A	B	C	D	E
GV-2000	2,830	705	225	1,125	1,000
GV-2500	3,080	705	225	1,375	1,000
GV-3000	3,750	760	275	1,545	1,500
GV-3500	4,000	760	275	1,795	1,500
GV-4000	4,950	760	275	2,190	2,000
GV-5000	6,285	795	325	3,140	2,350
GV-6000	7,435	925	325	3,510	3,000
GV-7000	10,300	950	550	5,050	4,300
GV-8000	10,300	950	550	5,050	4,300

Dual ram (2R series)

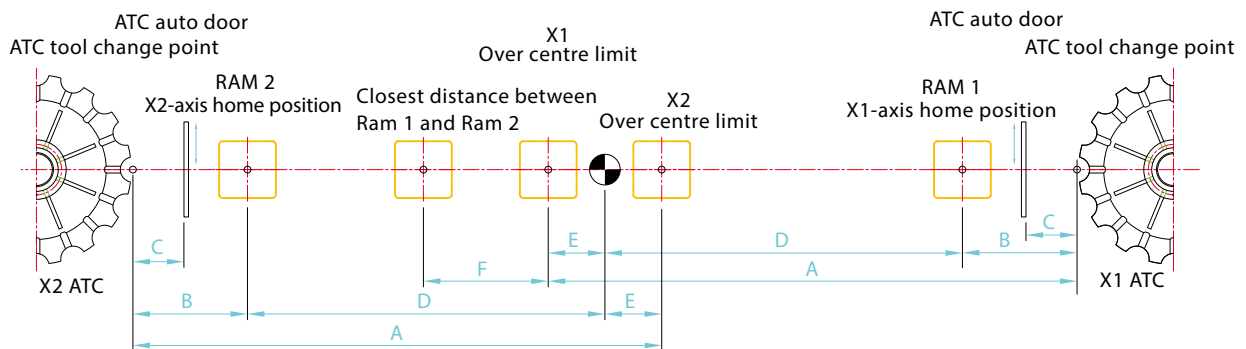

Model	A	B	C	D	E	F
GV-2000-2R	2,080	680	225	1,150	250	650
GV-2500-2R	2,330	680	225	1,400	250	650
GV-3000-2R	2,500	760	275	1,545	250	650
GV-3500-2R	2,750	760	275	1,795	250	650
GV-4000-2R	3,200	760	275	2,190	250	650
GV-5000-2R	4,185	795	325	3,140	250	650
GV-6000-2R	4,685	925	325	3,510	250	650
GV-7000-2R	6,250	950	550	5,050	250	650
GV-8000-2R	6,250	950	550	5,050	250	650

Working Range

Single Ram (1R series)

Dual ram (2R series)

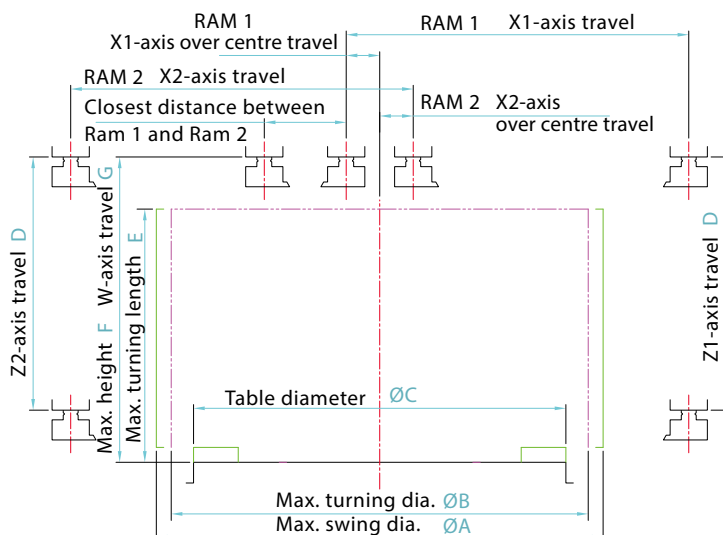
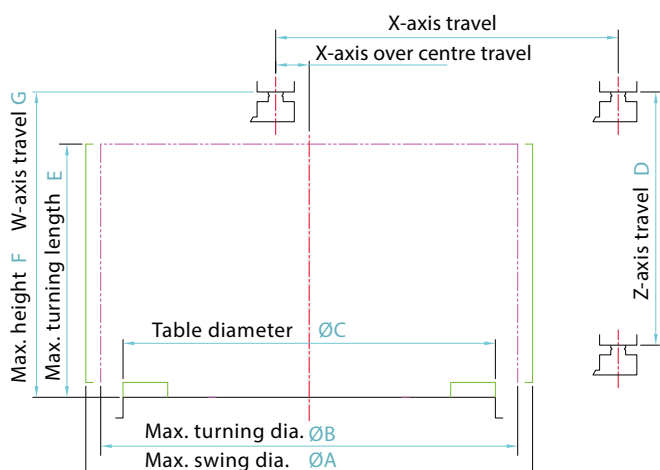

機型	A	B	C	D	E*1	F*1	G*1
GV-2000	2,500	2,300	2,000	1,200	1,700	2,050	1,200
GV-2500	3,000	2,800	2,500	1,200	1,700	2,050	1,200
GV-3000	3,700	3,500	3,000	1,500	1,800	2,200	1,200
GV-3500	4,200	4,000	3,500	1,500	1,800	2,200	1,200
GV-4000	4,700	4,500	4,000	1,500	1,800	2,200	1,200
GV-5000	6,400	6,000	5,000	1,600	3,200	3,570	2,400
GV-6000	7,500	7,000	6,000	1,600	3,200	3,570	2,400
GV-7000	9,000	8,500	7,000	1,600	3,400	3,875	2,400
GV-8000	9,500	9,000	8,000	1,600	3,400	3,875	2,400

*1 Change upon customer's requested

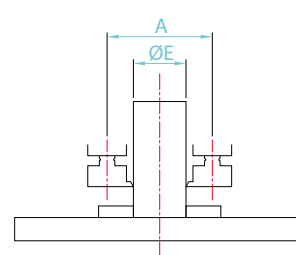
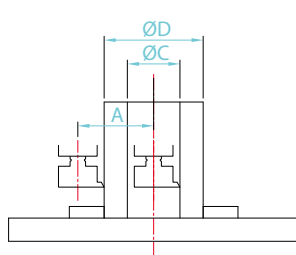
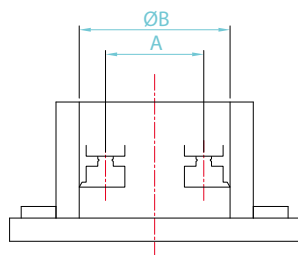

Model	A	B	C	D	E
GV-2000-2R	1,300	1,600	360	2,300	1,000
GV-2500-2R	1,300	1,600	360	2,300	1,000
GV-3000-2R	1,400	1,700	400	2,500	1,100
GV-3500-2R	1,400	1,700	400	2,500	1,100
GV-4000-2R	1,400	1,700	400	2,500	1,100
GV-5000-2R	1,900	2,430	530	3,300	1,400
GV-6000-2R	1,900	2,430	530	3,300	1,400
GV-7000-2R	2,000	2,530	530	3,470	1,470
GV-8000-2R	2,000	2,530	530	3,470	1,470



GLINC 350

Advanced hardware combined with intelligent software, makes your machine smarter

SVI Inspection

Brand New Inspection Strategy for Safer and More Efficient Working Experience (Optional)

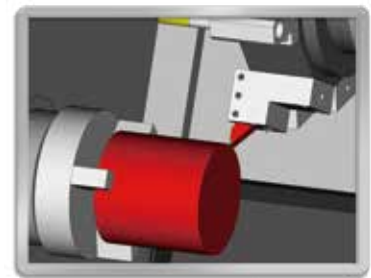
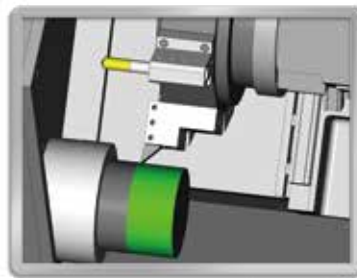

Create Simulation

Simulation Inspection

Interference Inspection

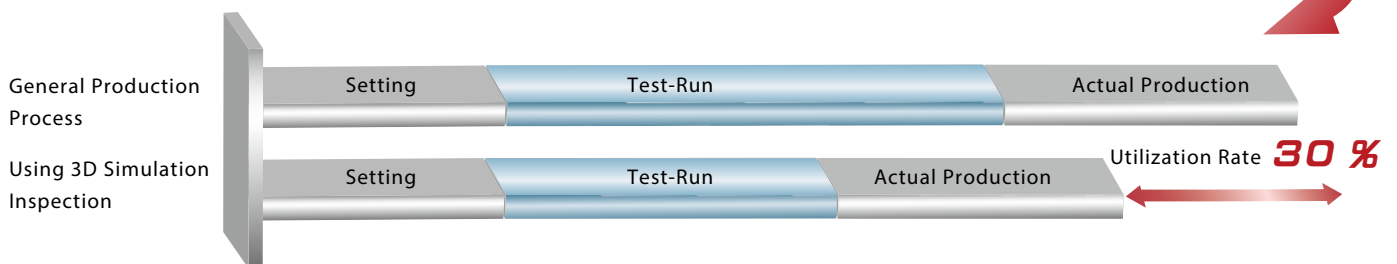

The 3D simulation inspection can greatly reduce test-run time and improve overall utilization rate

NEW GENERATION INTELLIGENT CONTROL SYSTEM

Features

- Advanced Hardware
- Reliable Continuous Operation
- Outstanding Operability
- Shortened Troubleshooting Time
- Streamlined Programming
- Improved Utilization Rate
- High Security and Shortened Machining Setting

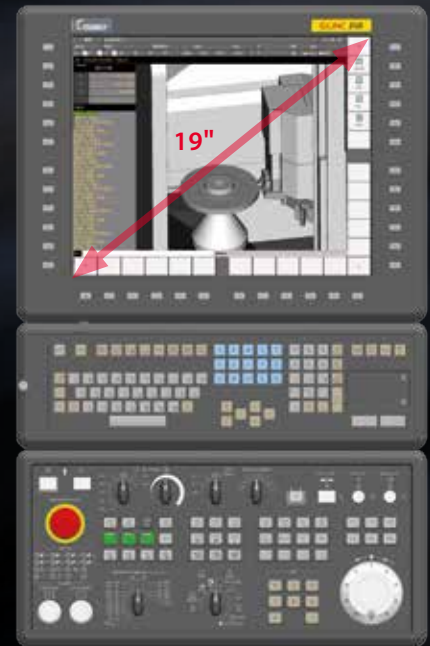

MT-Line Messages

Monitoring machine condition in real time

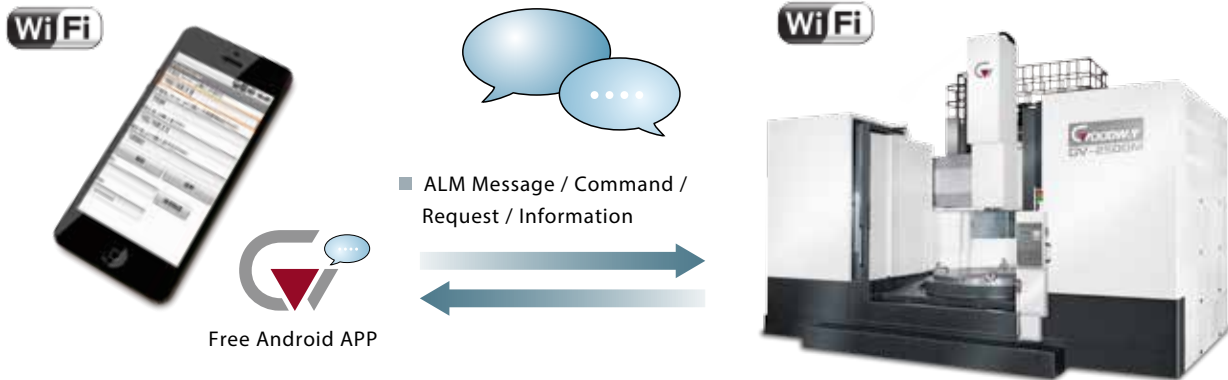

High Intelligent Machine Control

- 3D Check
- Tool Management
- Senesor Status
- Load Monitor
- Tool Build
- Alarm Detail
- Productive Management
- Position Screen



MACHINE SPECIFICATIONS

CAPACITY	GV-2000	GV-2500	GV-3000	GV-3500
Table diameter	Ø 2,000 mm	Ø 2,500 mm	Ø 3,000 mm	Ø 3,500 mm
Max. swing diameter	Ø 2,500 mm	Ø 3,000 mm	Ø 3,700 mm	Ø 4,200 mm
Max. turning diameter	Ø 2,300 mm	Ø 2,800 mm	Ø 3,500 mm	Ø 4,000 mm
Max. turning height	1,700 / 2,100 mm		1,800 / 2,200 / 2,800 / 3,200 mm	
Max. table load	10,000 Kg	15,000 Kg	20,000 / 45,000 Kg	20,000 / 45,000 Kg
WORK-PIECE SPINDLE				
Spindle bearing diameter	Ø 912 mm	Ø 1,180 mm	Bear / Hydrostatic (Opt.)	
Motor output (cont. / 30 min.)	60 / 75 kW		(40 / 50 kW) x 2	
Spindle drive system	2-step gear box			
Spindle speed range	1 ~ 200 rpm	1 ~ 160 rpm	1 ~ 120 rpm	1 ~ 120 rpm
Max. spindle torque	56,000 N-m	74,140 N-m	88,665 N-m	88,665 N-m
TOOLING SPINDLE (OPTIONAL)				
Motor output (cont. / 30 min.)	11 / 15 kW		15 / 18.5 kW	
Spindle speed range	24 ~ 2,400 rpm			
Cf-AXIS (OPTIONAL)				
Cf-axis servo motor output	5.5 kW		—*1	
Cf-axis speed range	6 rpm		—*1	
Cf-axis torque output	8,400 N-m	10,800 N-m	—*1	
X & Z AXES				
Max. X-axis travel	2,325 mm	2,575 mm	3,425 mm	3,675 mm
Max. Z-axis travel	1,200 mm		1,500 / 1,800 mm	
X / Z axes rapids	10 / 10 m/min		6 / 10 m/min	
X / Z axes motor output	6 kW		8.2 kW	
W-AXIS				
Max. W-axis travel	1,200 / 1,600 mm		1,200 / 1,600 / 2,200 / 2,600 mm	
W-axis rapids	300 mm/min		200 mm/min	
ATC				
Magazine capacity	16 T			
Spindle taper	BT50		BT50 (BT60 Opt.)	
Max. tool size (W x T x L)	280 x 150 x 400 mm		280 x 150 x 400 mm	
Max. tool weight	50 Kg		50 Kg	
Max. magazine load	360 Kg		800 Kg	
GENERAL				
Positioning accuracy	± 0.007 / 500 mm			
Repeatability	± 0.005 mm			
Standard CNC control	FANUC Oi -TD		SIEMENS SINUMERIK 840D sl	
Voltage requirement	AC400/440+10%to-15%3 phase			
Hydraulic capacity	130 L			
Coolant tank capacity	1,000 L	1,200 L	2,500 L	
Machine weight	50,000 Kg	55,000 Kg	70,000 Kg	90,000 Kg
Machine Dimensions (H)	6,895 mm	6,895 mm	7,600 mm	7,600 mm
Machine Dimensions (L x W)	7,040 x 4,610 mm	7,540 x 4,610 mm	9,500 x 8,500 mm	10,000 x 9,000 mm

*1 The series are designed with Cs-axis.

Specifications are subject to change without notice.

GV-4000	GV-5000	GV-6000	GV-7000	GV-8000
Ø 4,000 mm	Ø 5,000 mm	Ø 6,000 mm	Ø 7,000 mm	Ø 8,000 mm
Ø 4,700 mm	Ø 6,400 mm	Ø 7,500 mm	Ø 9,000 mm	Ø 9,500 mm
Ø 4,500 mm	Ø 6,000 mm	Ø 7,000 mm	Ø 8,500 mm	Ø 9,000 mm
1,800 / 2,200 / 2,800 / 3,200 mm	2,200 / 2,800 / 3,200 / 3,600 mm		2,600 / 3,400 / 4,200 / 5,000 mm	
30,000 / 60,000 Kg	100,000 Kg	150,000 Kg	250,000 Kg	300,000 Kg
Bear / Hydrostatic (Opt.)		Hydrostatic		
(40 / 50 kW) x 2		(60 / 71 kW) x 2	(100 / 126 kW) x 2	
2-step gear box				
1 ~ 60 rpm	1 ~ 60 rpm	1 ~ 25 rpm	1 ~ 20 rpm	1 ~ 20 rpm
216,500 N-m	293,300 N-m	356,200 N-m	450,980 N-m	450,980 N-m
17 / 20.5 kW				
24 ~ 2,400 rpm				
—*1				
—*1				
—*1				
4,445 mm	5,565 mm	6,715 mm	8,765 mm	9,015 mm
1,500 / 1,800 mm	1,600 / 2,000 mm		1,600 / 2,000 / 2,500 mm	
6 / 10 m/min				
8.2 kW				
1,200 / 1,600 / 2,200 / 2,600 mm	1,600 / 2,000 / 2,400 / 3,000 mm		1,600 / 2,400 / 3,200 / 4,000 mm	
200 mm/min				
16 T				
BT50 (BT60 Opt.)	BT50 (BT60 Opt.)			
280 x 150 x 400 mm	390 x 155 x 400 mm (BT60)			
50 Kg	50 / 80 (BT60) Kg			
800 Kg	800 / 1,200 (BT60) Kg			
± 0.007 / 500 mm				
± 0.005 mm				
SIEMENS SINUMERIK 840D sl				
AC400/440+10%to-15%3 phase				
130 L	350 L	350 L	350 L	350 L
2,500 L	2,500 L	3,500 L	6,800 L	6,800L
100,000 Kg	200,000 Kg	280,000 Kg	400,000 Kg	420,000 Kg
7,600 mm	9,600 mm	11,000 mm	12,000 mm	12,000 mm
10,500 x 9,600 mm	12,500 x 11,000 mm	20,000 x 12,000 mm	23,000 x 15,500 mm	23,000 x 15,500 mm



GOODWAY MACHINE CORP.

Headquarters

No.13, 5th Road,
Taichung Industrial Park,
Taichung City, 407, Taiwan, R.O.C.
Website : www.goodwaycnc.com
E-mail : goodway@goodwaycnc.com

Central Taiwan Science Park Branch

No. 38, Keyuan Road,
Central Taiwan Science Park.Taichung,
Taichung City, 407, Taiwan, R.O.C.
TEL : + 886-4-2463-6000
FAX : + 886-4-2463-9600

GOODWAY (SUZHOU) MACHINE CORP.

No.589, Chengyang Road,
Xiang Cheng Economic Development District
Suzhou City, Jiangsu, China
TEL : + 86-512-6576-3699
FAX : + 86-512-6576-7299
E-mail : goodway.suzhou@goodwaycnc.com.tw